



Operator's Manual

Serial Number Range

SX-105 XC™
SX-125 XC™

From SX105D-174

From SX125D-101

CE

with
Maintenance
Information

Original Instructions
First Edition
Second Printing
Part No. 1270327



Contents

Introduction	1
Symbol and Hazard Pictorials Definitions.....	4
General Safety	6
Personal Safety.....	9
Work Area Safety.....	10
Legend	18
Controls.....	19
Inspections.....	28
Operating Instructions.....	42
Transport and Lifting Instructions	53
Maintenance	58
Specifications.....	61

Copyright © 2016 by Terex Corporation

First Edition: Second Printing, July 2017

Genie is a registered trademark of Terex South Dakota, Inc. in the U.S.A. and many other countries.

"XC" is a trademark of Terex South Dakota, Inc.

 Complies with EC Directive 2006/42/EC
See EC Declaration of Conformity

Introduction

About this manual

Genie appreciates your choice of our machine for your application. Our number one priority is user safety, which is best achieved by our joint efforts. This book is an operation and daily maintenance manual for the user or operator of a Genie machine.

This manual should be considered a permanent part of your machine and should remain with the machine at all times. If you have any questions, contact Genie.

Product Identification

The machine serial number is located on the serial label.

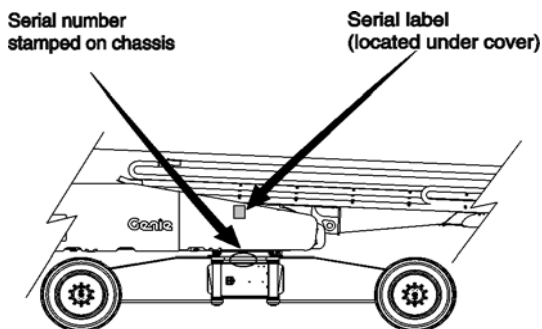

Intended Use

This machine is intended to be used only to lift personnel, along with their tools and materials to an aerial work site.

Bulletin Distribution and Compliance

Safety of product users is of paramount importance to Genie. Various bulletins are used by Genie to communicate important safety and product information to dealers and machine owners.

The information contained in the bulletins is tied to specific machines using the machine model and serial number.

Distribution of bulletins is based on the most current owner on record along with their associated dealer, so it is important to register your machine and keep your contact information up to date.

To ensure safety of personnel and the reliable continued operation of your machine, be sure to comply with the action indicated in a respective bulletin.

Introduction

Contacting the Manufacturer

At times it may be necessary to contact Genie. When you do, be ready to supply the model number and serial number of your machine, along with your name and contact information. At minimum, Genie should be contacted for:

Accident reporting

Questions regarding product applications and safety

Standards and regulatory compliance information

Current owner updates, such as changes in machine ownership or changes in your contact information. See Transfer of Ownership, below.

Transfer of Machine Ownership

Taking a few minutes to update owner information will ensure that you receive important safety, maintenance and operating information that applies to your machine.

Please register your machine by visiting us on the web at www.genielift.com or by calling us toll free at 1-800-536-1800.



Danger

Failure to obey the instructions and safety rules in this manual will result in death or serious injury.

Do Not Operate Unless:

- You learn and practice the principles of safe machine operation contained in this operator's manual.
 - 1 Avoid hazardous situations.**
 - Know and understand the safety rules before going on to the next section.**
 - 2 Always perform a pre-operation inspection.
 - 3 Always perform function tests prior to use.
 - 4 Inspect the workplace.
 - 5 Only use the machine as it was intended.
- You read, understand and obey the manufacturer's instructions and safety rules—safety and operator's manuals and machine decals.
- You read, understand and obey employer's safety rules and worksite regulations.
- You read, understand and obey all applicable governmental regulations.
- You are properly trained to safely operate the machine.



Introduction

Safety Sign Maintenance

Replace any missing or damaged safety signs. Keep operator safety in mind at all times. Use mild soap and water to clean safety signs. Do not use solvent-based cleaners because they may damage the safety sign material.

Hazard Classification

Decals on this machine use symbols, color coding and signal words to identify the following:



Safety alert symbol—used to alert you to potential personal injury hazards. Obey all safety messages that follow this symbol to avoid possible injury or death.

▲ DANGER

Indicates a hazardous situation which, if not avoided, will result in death or serious injury.

▲ WARNING

Indicates a hazardous situation which, if not avoided, could result in death or serious injury.

▲ CAUTION

Indicates a hazardous situation which, if not avoided, could result in minor or moderate injury.

NOTICE









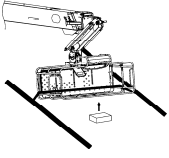
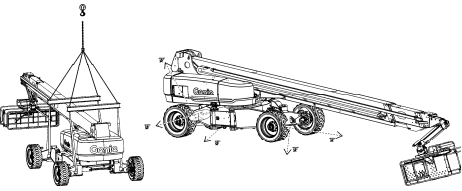

Indicates a property damage message.

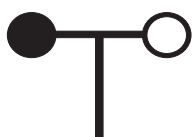
Symbol and Hazard Pictorials Definitions

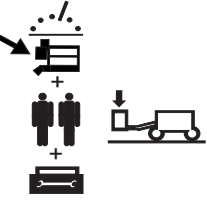
				
Crushing hazard	Keep away from moving parts	Crush hazard	Overhead obstruction	Collision hazard
				
Electrocution hazard	Maintain required clearance	Tip-over hazard	Tip-over hazard	Tip-over hazard
				
Electrocution hazard	Avoid contact	Disconnect battery	Read the operator's manual	Read the operator's manual
				
Explosion hazard	No smoking. No flame. Stop engine.	Explosion hazard	Burn hazard	Fire extinguisher
				
Fire hazard	No smoking	Explosion hazard	No step	Lanyard anchorage points

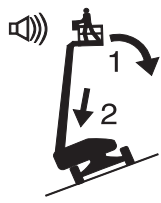
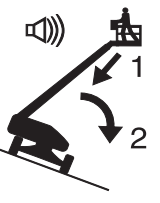

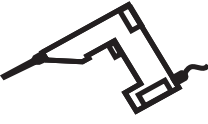
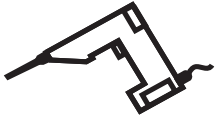
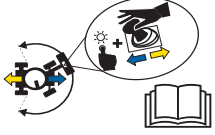
Symbol and Hazard Pictorials Definitions

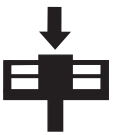
 <p>Platform tie-down instructions</p>	 <p>Lifting & tie down instructions</p>		 <p>Tie-down point</p>	 <p>Lifting point</p>
 <p>Wind speed</p>	 <p>Runaway Hazard</p>	 <p>Weight of welder reduces capacity</p>	 <p>Wheel load</p>	 <p>Tire specifications</p>
<p>Recovery procedure if tilt alarm sounds while elevated.</p>   <p>Platform uphill: 1 Lower boom. 2 Retract boom.</p> <p>Platform downhill: 1 Retract boom. 2 Lower boom.</p>		 <p>Do not use ether or other high energy starting aids on machines equipped with glow plugs.</p>	 <p>Voltage rating for power to platform</p>	 <p>Pressure rating for air line to platform</p>
 <p>Color Coded Direction Arrows</p>	 <p>Manual force</p>	 <p>Access by trained and authorized personnel only</p>	 <p>Maximum capacity</p>	

General Safety

82487



1263542



133067



114252



114249



82481



T114286

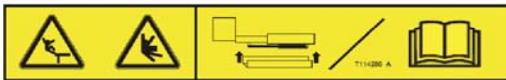

1256425



133205

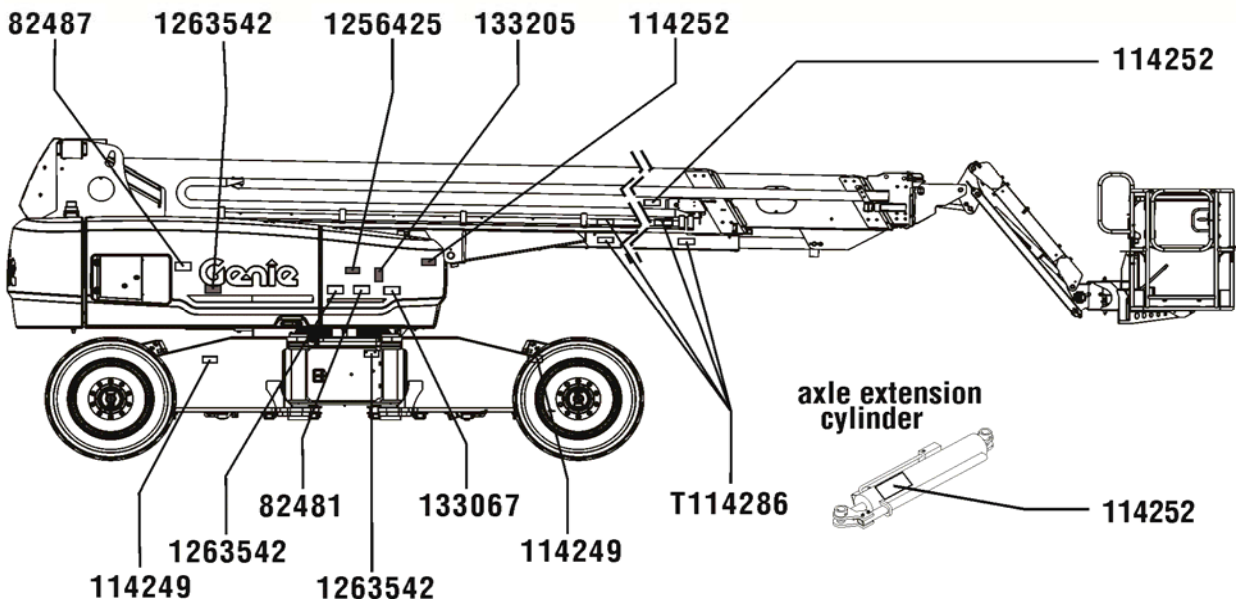



General Safety

219958



1272508



1280580



133067



114473



219958

**1280580
or 1272508**

1278374

114473

82487

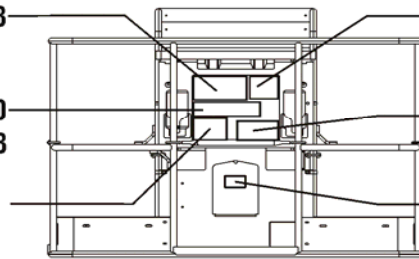

82487

1278374



82487



General Safety

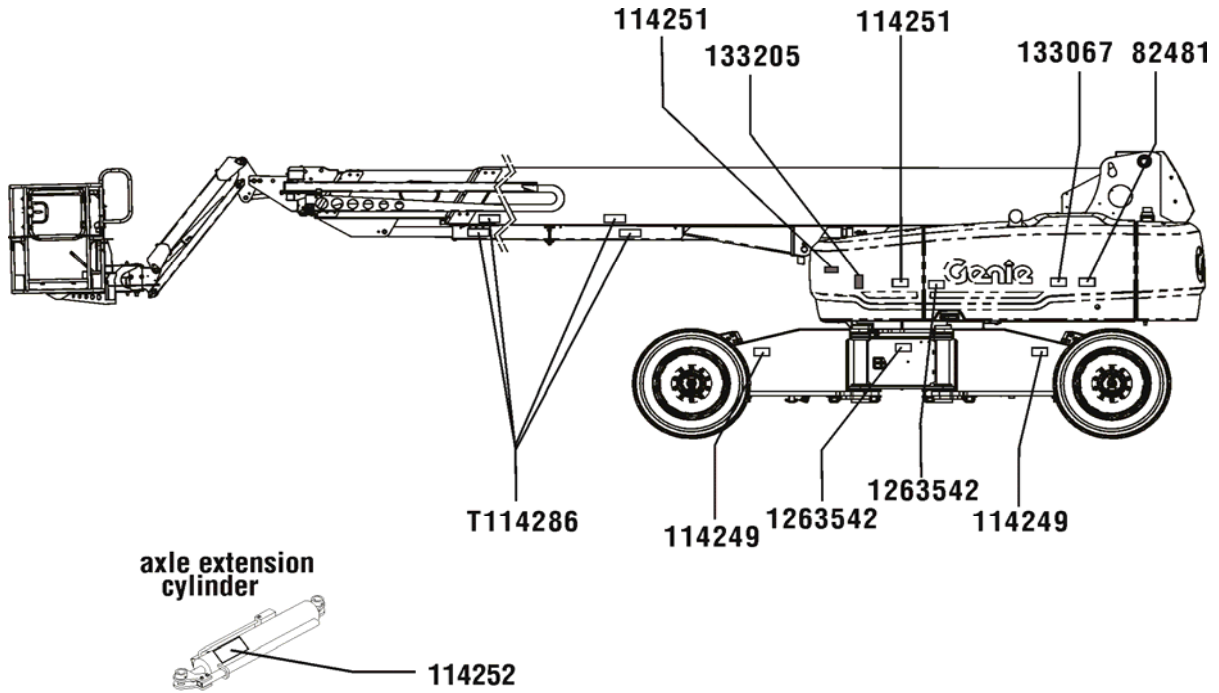

114249



1263542



133067



114251



114252



82481



T114286

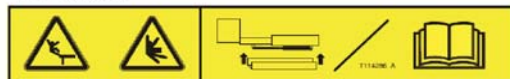

133205





Personal Safety

Personal Fall Protection

Personal fall protection equipment (PFPE) is required when operating this machine.

Occupants must wear a safety belt or harness in accordance with governmental regulations. Attach the lanyard to the anchor provided in the platform.

Operators must comply with employer, job site and governmental rules regarding the use of personal protective equipment.

All PFPE must comply with applicable governmental regulations, and must be inspected and used in accordance with the PFPE manufacturer's instructions.



Work Area Safety

⚠ Electrocuting Hazards

This machine is not electrically insulated and will not provide protection from contact with or proximity to electrical current.

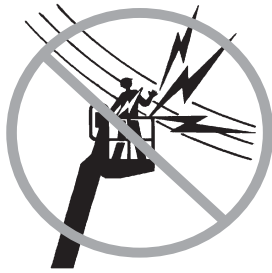

Obey all local and governmental regulations regarding required clearance from electrical power lines. At a minimum, the required clearance contained in the chart below must be followed.

Line Voltage	Required Clearance
0 to 50KV	3.05 m
50 to 200KV	4.60 m
200 to 350KV	6.10 m
350 to 500KV	7.62 m
500 to 750KV	10.67 m
750 to 1000KV	13.72 m

Allow for platform movement, electrical line sway or sag, and beware of strong or gusty winds.

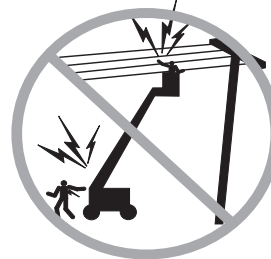

Keep away from the machine if it contacts energized power lines. Personnel on the ground or in the platform must not touch or operate the machine until energized power lines are shut off.

Do not operate the machine during lightning or storms.

Do not use the machine as a ground for welding.

⚠ Tip-over Hazards

Occupants, equipment and materials shall not exceed the maximum platform capacity for the restricted or unrestricted range of motion.

Unrestricted range of motion

Maximum platform capacity	300 kg
Maximum occupants	2

Restricted range of motion

Maximum platform capacity	454 kg
Maximum occupants	3

If the platform load is greater than 300 kg, do not move the platform into the unrestricted range of motion zone.

Do not exceed the maximum platform capacity.

Do not attach a platform rated at 300 kg (unrestricted range of motion) or 454 kg (restricted range of motion) to machines with any other rated load. See the serial label for the maximum rated load.



Work Area Safety

The weight of options and accessories such as pipe cradles and welders will reduce the rated platform capacity, and must be subtracted from the platform capacity. See the decals with the options and accessories.

If using accessories, read, understand and obey the decals, instructions and manuals with the accessory.



Do not raise or extend the boom unless the machine is on a firm, level surface.



Do not depend on the tilt alarm as a level indicator. The tilt alarm sounds in the platform only when the machine is on a severe slope.

If the tilt alarm sounds when the platform is raised, use extreme caution. The machine not level indicator light will come on and the drive function in one or both directions will not operate. Identify the condition of the boom on the slope as shown below. Follow the steps to lower the boom before moving to a firm, level surface. Do not rotate the boom while lowering.

The recovery mode should be used only by trained and authorized personnel.

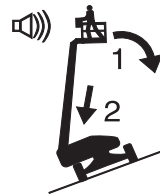

If the tilt alarm sounds with the platform uphill:

- 1 Lower the boom.
- 2 Retract the boom.

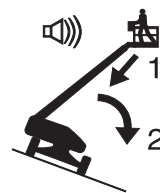

If the tilt alarm sounds with the platform downhill:

- 1 Retract the boom.
- 2 Lower the boom.



Do not raise the boom when wind speeds may exceed 12.5 m/s. If wind speeds exceed 12.5 m/s when the boom is raised, lower the boom and do not continue to operate the machine.

Do not operate the machine in strong or gusty winds. Do not increase the surface area of the platform or the load. Increasing the area exposed to the wind will decrease machine stability.

Work Area Safety



Use extreme care and slow speeds while driving the machine in the stowed position across uneven terrain, debris, unstable or slippery surfaces and near holes and drop-offs.

Do not drive the machine on or near uneven terrain, unstable surfaces or other hazardous conditions with the boom raised or extended.

Do not use the machine as a crane.

Do not push the machine or other objects with the boom.

Do not contact adjacent structures with the boom.

Do not tie the boom or platform to adjacent structures.

Do not place loads outside the platform perimeter.

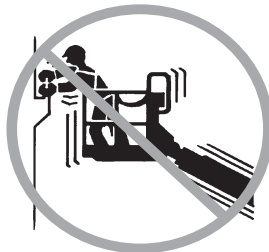

Do not push off or pull toward any object outside of the platform.

**Maximum allowable
manual force – CE**
400 N

Do not alter or disable machine components that in any way affect safety and stability.

Do not replace items critical to machine stability with items of different weight or specification.

Do not replace factory-installed tires with tires of different specification or ply rating.

Do not use air-filled tires. These machines are equipped with foam-filled tires. Wheel weight is critical to stability.

Do not use the platform controls to free a platform that is caught, snagged or otherwise prevented from normal motion by an adjacent structure. All personnel must be removed from the platform before attempting to free the platform using the ground controls.

Do not modify or alter an aerial work platform without prior written permission from the manufacturer. Mounting attachments for holding tools or other materials onto the platform, toeboards or guard rail system can increase the weight in the platform and the surface area of the platform or the load.

Work Area Safety



Do not place or attach fixed or overhanging loads to any part of this machine.



Do not place ladders or scaffolds in the platform or against any part of this machine.

Do not transport tools and materials unless they are evenly distributed and can be safely handled by person(s) in the platform.

Do not use the machine on a moving or mobile surface or vehicle.

Be sure the tires are in good condition and the lug nuts tightened.

⚠ Operation on Slopes Hazards

Do not drive the machine on a slope that exceeds the maximum uphill, downhill or side slope rating of the machine. Slope rating applies only to machines in the stowed position.

Maximum slope rating, stowed position

Platform downhill	40% (22°)
Platform uphill	40% (22°)
Side slope	25% (14°)

Note: Slope rating is subject to ground conditions with one person in the platform and adequate traction. Additional platform weight may reduce slope rating. See Driving on a Slope in the Operating Instructions section.

Work Area Safety

▲ Fall Hazards



Occupants must wear a safety belt or harness in accordance with governmental regulations. Attach the lanyard to the anchor provided in the platform.



Do not sit, stand or climb on the platform guard rails. Maintain a firm footing on the platform floor at all times.



Do not climb down from the platform when raised.

Keep the platform floor clear of debris.

Lower the platform entry mid-rail or close the entry gate before operating.

Do not enter or exit the platform unless the machine is in the stowed position and the platform is at ground level.

▲ Collision Hazards

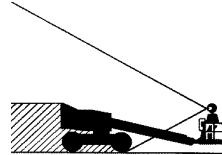

Be aware of limited sight distance and blind spots when driving or operating.

Be aware of the boom position and tailswing when rotating the turntable.



Check the work area for overhead obstructions or other possible hazards.



Be aware of crushing hazards when grasping the platform guard rail.

Operators must comply with employer, job site and governmental rules regarding use of personal protective equipment.

Work Area Safety

Observe and use the color-coded direction arrows on the platform controls and drive chassis for drive and steer functions.



Do not lower the boom unless the area below is clear of personnel and obstructions.



Limit travel speed according to the condition of the ground surface, congestion, slope, location of personnel, and any other factors which may cause collision.

Do not operate a boom in the path of any crane unless the controls of the crane have been locked out and/or precautions have been taken to prevent any potential collision.

No stunt driving or horseplay while operating a machine.

▲ Bodily Injury Hazard

Always operate the machine in a well-ventilated area to avoid carbon monoxide poisoning.

Do not operate the machine with a hydraulic oil or air leak. An air leak or hydraulic leak can penetrate and/or burn skin.

Improper contact with components under any cover will cause serious injury. Only trained maintenance personnel should access compartments. Access by the operator is only advised when performing a pre-operation inspection. All compartments must remain closed and secured during operation.

▲ Explosion and Fire Hazards

Do not start the engine if you smell or detect liquid petroleum gas (LPG), gasoline, diesel fuel or other explosive substances.

Do not refuel the machine with the engine running.

Refuel the machine and charge the battery only in an open, well-ventilated area away from sparks, flames and lighted tobacco.

Do not operate the machine or charge the battery in hazardous locations or locations where potentially flammable or explosive gases or particles may be present.

Do not spray ether into engines equipped with glow plugs.

Work Area Safety

⚠ Damaged Machine Hazards

Do not use a damaged or malfunctioning machine.

Conduct a thorough pre-operation inspection of the machine and test all functions before each work shift. Immediately tag and remove from service a damaged or malfunctioning machine.

Be sure all maintenance has been performed as specified in this manual and the appropriate Genie service manual.

Be sure all decals are in place and legible.

Be sure the operator's, safety and responsibilities manuals are complete, legible and in the storage container located on the machine.

⚠ Component Damage Hazards

Do not use any battery or charger greater than 12V to jump-start the engine.

Do not use the machine as a ground for welding.

Do not operate the machine in locations where extremely high magnetic fields may be present.

⚠ Battery Safety

Burn Hazards



Batteries contain acid. Always wear protective clothing and eye wear when working with batteries.

Avoid spilling or contacting battery acid. Neutralize battery acid spills with baking soda and water.

Explosion Hazards



Keep sparks, flames and lighted tobacco away from batteries. Batteries emit explosive gas.

⚠ Electrocutation Hazard

Avoid contact with electrical terminals.



Work Area Safety

▲ Pipe Cradle Safety

Read, understand and obey all warnings and instructions provided with the pipe cradles.

Do not exceed the rated platform capacity. The pipe cradle assembly and the weight in the pipe cradles will reduce rated platform capacity and must be factored into total platform load.

The pipe cradle assembly weighs 9.5 kg.

The maximum capacity of the pipe cradle assembly is 91 kg.

The weight of the pipe cradle assembly and the load in the pipe cradles may limit the maximum number of occupants in platform.

Center the load within the perimeter of the platform.

Secure the load to the platform.

Do not obstruct the entrance or the exit of the platform.

Do not obstruct the ability to operate the platform controls or the red Emergency Stop button.

Do not operate unless you are adequately instructed and are aware of all of the hazards associated with movement of the platform with an overhanging load.

Do not cause a horizontal force or side load to machine by raising or lowering a fixed or overhanging load.

Electrocution Hazard: Keep pipes away from all energized electrical conductors.

▲ Welder Safety

Read, understand and obey all warnings and instructions provided with the welding power unit.

Do not connect weld leads or cables unless the welding power unit is turned off at the platform controls.

Do not operate unless the weld cables are properly connected and the welder is properly grounded.

The weight of the welder will reduce the rated platform capacity and must be factored into the total platform load. The welder power supply weighs 34 kg.

Do not operate the welder unless a fire extinguisher is immediately available for instant use, per OSHA regulation 1926.352(d).

Lockout After Each Use

- 1 Select a safe parking location—firm level surface, clear of obstruction and traffic.
- 2 Retract and lower the boom to the stowed position.
- 3 Rotate the turntable until the boom is positioned between the circle end wheels.
- 4 Turn the key switch to the off position and remove the key to secure from unauthorized use.

Legend

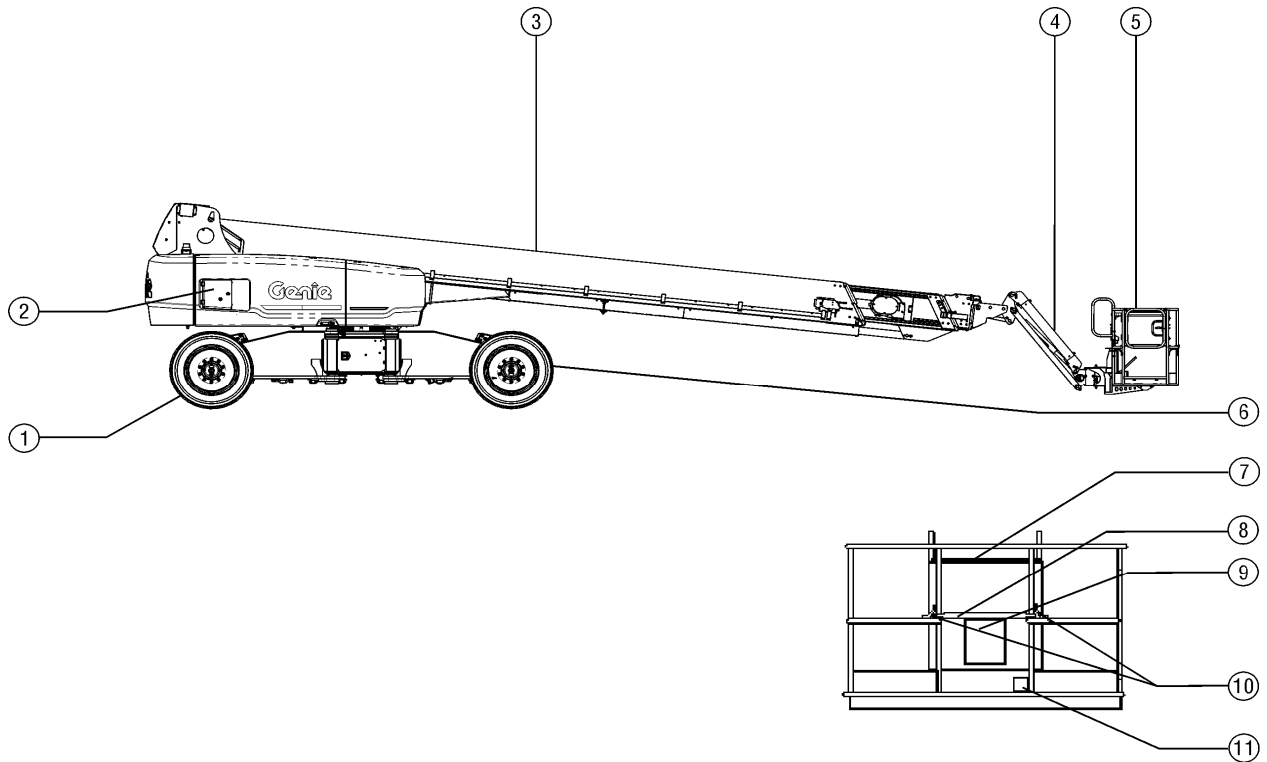

- 1 Square-end tire
- 2 Ground controls
- 3 Boom
- 4 Jib boom
- 5 Platform
- 6 Circle-end tire

- 7 Platform controls
- 8 Sliding mid-rail
- 9 Manual storage container
- 10 Lanyard anchorage points
- 11 Foot switch

Controls

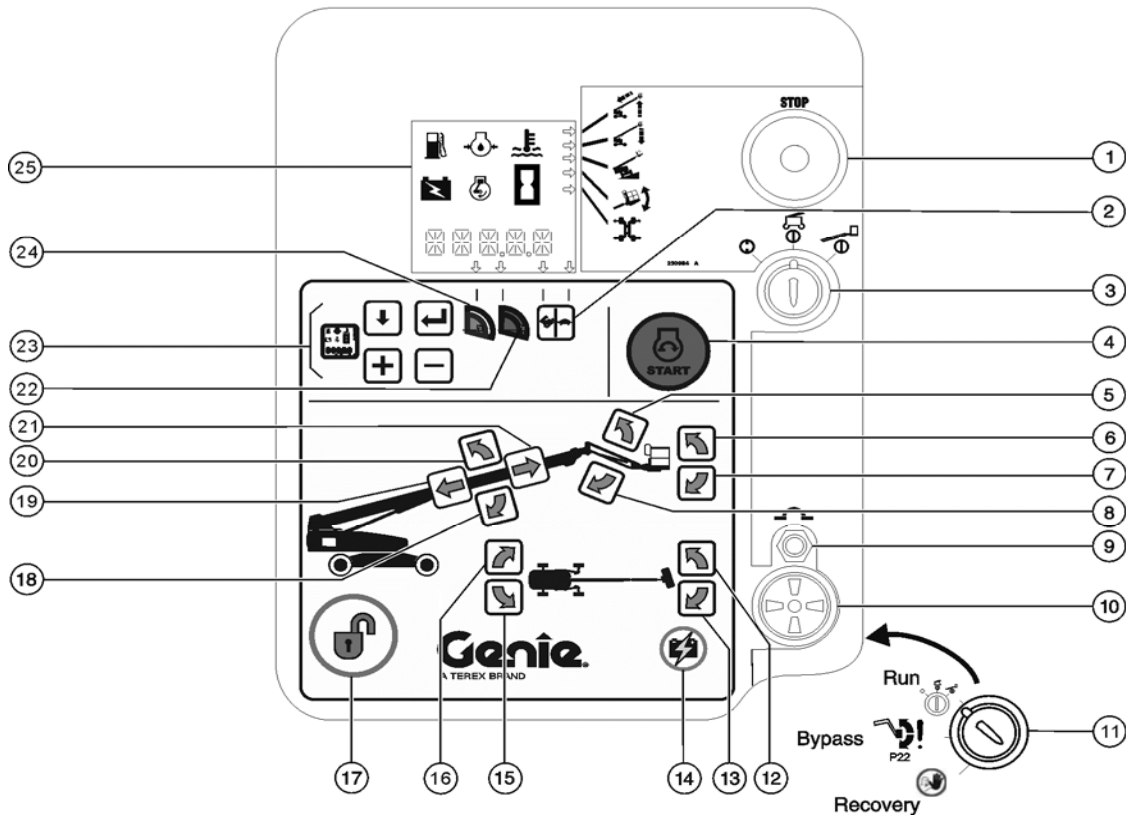

Ground Control Panel

- | | | |
|--|----------------------------------|---|
| 1 Red Emergency Stop button | 10 Alarm | 19 Boom retract button |
| 2 Function speed select buttons | 11 Bypass/recovery key switch | 20 Boom up button |
| 3 Key switch for off/ground/platform selection | 12 Platform rotate right button | 21 Boom extend button |
| 4 Engine start button | 13 Platform rotate left button | 22 Unrestricted range of motion indicator light |
| 5 Jib boom up button | 14 Emergency power button | 23 LCD screen control buttons |
| 6 Platform level up button | 15 Turntable rotate left button | 24 Restricted range of motion indicator light |
| 7 Platform level down button | 16 Turntable rotate right button | 25 LCD readout screen |
| 8 Jib boom down button | 17 Function enable button | |
| 9 20A circuit breaker for system circuit | 18 Boom down button | |



Controls

Ground Control Panel

- 1 Red Emergency Stop button
Push in the red Emergency Stop button to the off position to stop all functions and turn the engine off. Pull out the red Emergency Stop button to the on position to operate the machine.
- 2 Function speed select buttons
Push the function speed select button to select function speed. When the arrow above the turtle is lit, machine functions will operate at slow speed. When the arrow above the rabbit is lit, machine functions will operate at fast speed.
- 3 Key switch for off/ground/platform selection
Turn the key switch to the off position and the machine will be off. Turn the key switch to the ground position and the ground controls will operate. Turn the key switch to the platform position and the platform controls will operate.
- 4 Engine start button
Press the engine start button to start the engine.
- 5 Jib boom up button
Press the jib boom up button and the jib boom will raise.
- 6 Platform level up button
Press the platform level up button and the level of the platform will raise.
- 7 Platform level down button
Press the platform level down button and the level of the platform will lower.
- 8 Jib boom down button
Press the jib boom down button and the jib boom will lower.
- 9 20A circuit breaker for system circuit
- 10 Alarm
- 11 Bypass/recovery key switch
Bypass key position to be used only to level the platform if the ground control display shows platform out of level (P22) and platform level controls do not work. Refer to the operating instructions.
Recovery key position should be used only by trained and authorized personnel.
- 12 Platform rotate right button
Press the platform rotate right button and the platform will rotate right.
- 13 Platform rotate left button
Press the platform rotate left button and the platform will rotate left.
- 14 Emergency power button
Use emergency power if the primary power source (engine) fails. Simultaneously hold the emergency power button and activate the desired function.
- 15 Turntable rotate left button
Press the turntable rotate left button and the turntable will rotate left.



Controls

16 Turntable rotate right button

Press the turntable rotate right button and the turntable will rotate right.

17 Function enable button

Press the function enable button to enable the functions on the ground control panel to operate at a speed.

18 Boom down button

Press the boom down button and the boom will lower.

19 Boom retract button

Press the boom retract button and the boom will retract.

20 Boom up button

Press the boom up button and the boom will raise.

21 Boom extend button

Press the boom extend button and the boom will extend.

22 Unrestricted range of motion indicator light

Light on indicates that the range of motion is unrestricted.

23 LCD screen control buttons

24 Restricted range of motion indicator light

Light on indicates that the range of motion is restricted.

25 LCD readout screen



- a low fuel indicator
- b engine oil pressure indicator
- c water temperature indicator
- d emergency power indicator
- e engine rpm indicator
- f hour meter

Controls

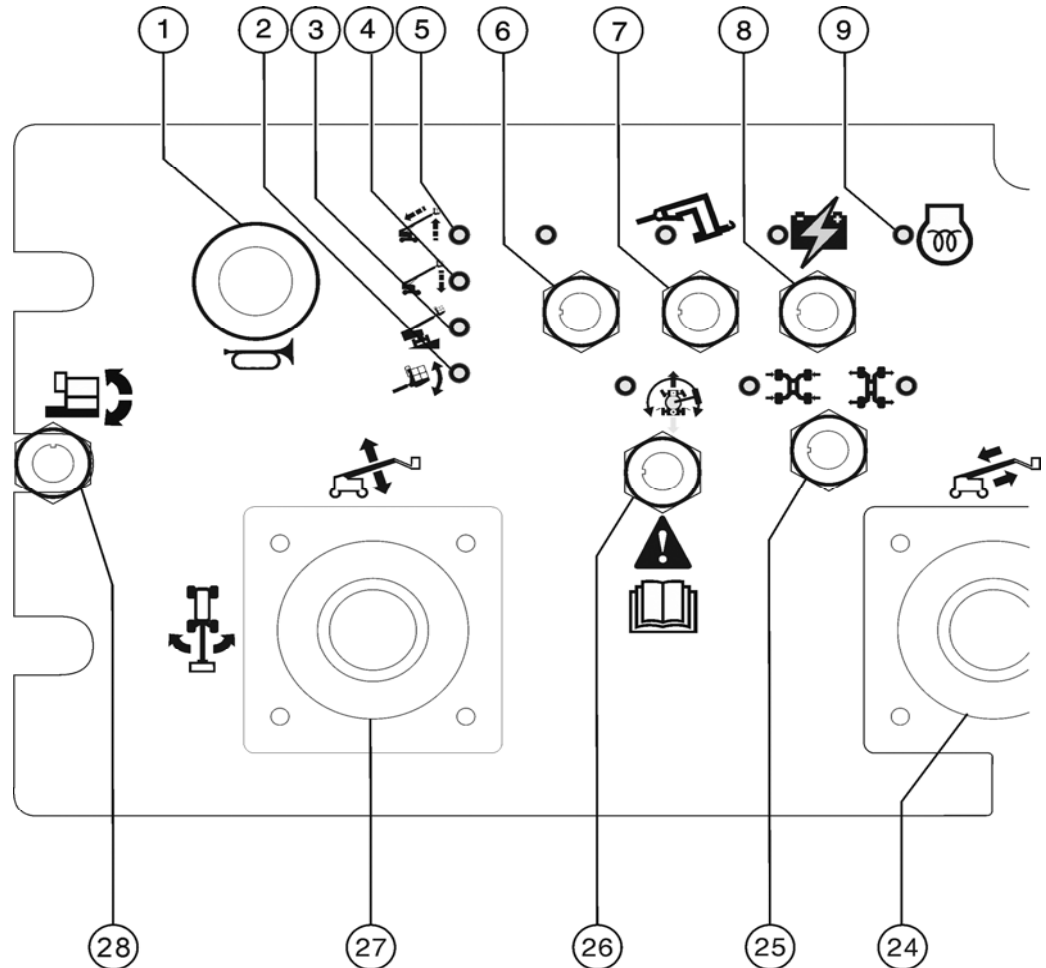

Platform Control Panel

- | | | | | | |
|---|---------------------------------------|---|---|--------------------------|--|
| 1 | Horn button | 8 | Emergency power switch with indicator light | 13 | Unrestricted range of motion indicator light |
| 2 | Platform not level indicator light | 9 | Diesel models: Glow plug indicator light | 14 | Platform overload indicator light |
| 3 | Machine on incline indicator light | 10 | Engine start switch with indicator light | 15 | Power indicator light |
| 4 | Lower boom indicator light | 11 | Engine idle select switch with indicator light: | 16 | Check engine indicator light |
| 5 | Raise/retract boom indicator light | <ul style="list-style-type: none"> • Rabbit: high idle • Turtle: low idle | 17 | Low fuel indicator light | |
| 6 | Used for optional equipment | 12 | Restricted range of motion indicator light | 18 | Fault indicator light |
| 7 | Generator switch with indicator light | | | 19 | Red Emergency Stop button |

Controls

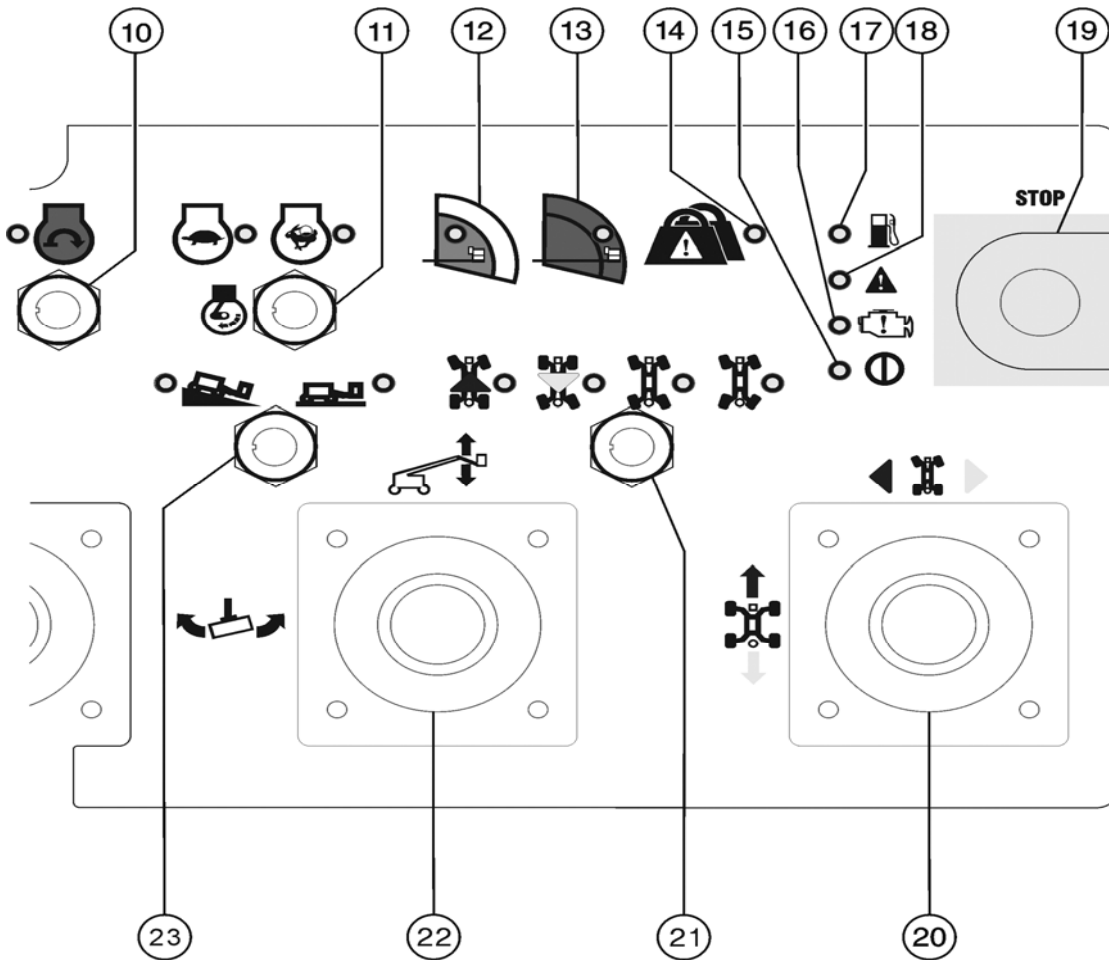

- 20 Dual axis proportional control handle for drive and steer functions
OR Proportional control handle for drive function and thumb rocker for steer function
- 21 Steer mode select switch with indicator lights
- 22 Dual axis proportional control handle for jib boom up/down and platform rotate left/right functions

- 23 Drive select switch with indicator lights
Machine on incline symbol: Low range operation for inclines
Machine on level surface symbol: High range operation for maximum drive speed
- 24 Single axis proportional control handle for boom extend/retract function

- 25 Axle extend/retract switch with indicator lights
- 26 Drive enable switch with indicator light
- 27 Dual axis proportional control handle for boom up/down and turntable rotate left/right functions
- 28 Platform level switch



Controls

Platform Control Panel

- 1 **Horn button**
Press this button and the horn will sound. Release the button and the horn will stop.
- 2 **Platform not level indicator light**
Level the platform until the light is off. The platform level toggle switch will only work in the direction that will level the platform.
- 3 **Machine on incline indicator light**
Light on indicates all functions have stopped. See the instructions in the Operating Instruction section.
- 4 **Lower boom indicator light**
Lower the boom until the light is off.
- 5 **Raise/retract boom indicator light**
Raise/retract the boom until the light is off.
- 6 **Used for optional equipment**
- 7 **Generator switch with indicator light**
Move the generator switch to turn the generator on. Move the switch again to turn the generator off.
- 8 **Emergency power switch with indicator light**
Use emergency power if the primary power source (engine) fails. Push down the foot switch and simultaneously move the emergency power switch and activate the desired function. The indicator light will be on when emergency power is being used.
- 9 **Diesel models: Glow plug indicator light**
Light on indicates the glow plug has been activated.
- 10 **Engine start switch with indicator light**
Move the engine start switch and the engine will start. The engine start indicator light will flash during engine start up and will turn solid once the engine is running.
- 11 **Engine idle select switch with indicator light:**
Move this switch to select engine idle setting. Rabbit symbol light on indicates high idle is selected. Turtle symbol light on indicates low idle is selected.

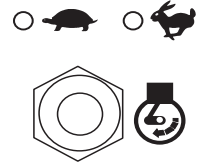



Controls

- | | |
|---|---|
| <p>12 Restricted range of motion indicator light
Light on indicates that the range of motion is restricted.</p> <p>13 Unrestricted range of motion indicator light
Light on indicates that the range of motion is unrestricted.</p> <p>14 Platform overload indicator light
Light flashing indicates the platform is overloaded. The engine will stop and no functions will operate. Remove weight until the light goes off and then restart the engine.</p> <p>15 Power indicator light
Light on indicates the machine is on.</p> <p>16 Check engine indicator light
Light on indicates an engine fault.</p> <p>17 Low fuel indicator light
Light on indicates the machine is low on fuel.</p> <p>18 Fault indicator light
Light on indicates a system fault.</p> <p>19 Red Emergency Stop button
Push in the red Emergency Stop button to the off position to stop all functions and turn the engine off. Pull out the red Emergency Stop button to the on position to operate the machine.</p> | <p>20 Dual axis proportional control handle for drive and steer functions
OR Proportional control handle for drive function and thumb rocker for steer function.</p> <p>Move the control handle in the direction indicated by the blue arrow on the control panel and the machine will drive forward. Move the control handle in the direction indicated by the yellow arrow and the machine will drive backwards. Move the control handle in the direction indicated by the blue triangle and the machine will steer to the left. Move the control handle in the direction indicated by the yellow triangle and the machine will steer to the right.</p> <p>OR</p> <p>Move the control handle in the direction indicated by the blue arrow on the control panel and the machine will drive forward. Move the control handle in the direction indicated by the yellow arrow and the machine will drive backwards. Press the left side of the thumb rocker and the machine will steer to the left. Press the right side of the thumb rocker and the machine will steer to the right.</p> |
|---|---|

Controls

21 Steer mode select switch with indicator lights

Move the steer mode select switch to choose steer mode. The indicator light next to the current steer mode will be on.

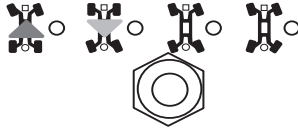

22 Dual axis proportional control handle for jib boom up/down and rotate left/right functions

Move the control handle up and the jib boom will raise. Move the control handle down and the jib boom will lower.

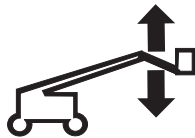

Move the control handle to the left and the platform will rotate left. Move the control handle to the right and the platform will rotate right.



23 Drive select switch with indicator lights

Move the drive select switch to choose drive setting. The indicator light next to the current setting will be on.

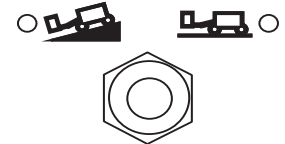

Machine on incline symbol: Low range operation for inclines.

Machine on level surface symbol: High range operation for maximum drive speed.

24 Single axis proportional control handle for boom extend/retract function

Move the control handle down and the boom will extend. Move the control handle up and the boom will retract.



Controls

25 Axle extend/retract switch with indicator lights

Move the axle select switch to choose an axle setting. The axle extend and retract indicator lights will flash while the axles are moving. The axle extend indicator light will stay on when the axles are fully extended. The axle retract indicator light will stay on when the axles are fully retracted.

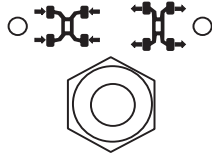

26 Drive enable switch with indicator light

Light on indicates that the boom has moved past a circle-end tire and the drive function has been interrupted. To drive, move the drive enable switch and slowly move the drive control handle off center. Use the color-coded direction arrows on the platform box and drive chassis to identify the direction the machine will travel.



27 Dual axis proportional control handle for boom up/down and turntable rotate left/right functions

Move the control handle up and the boom will raise. Move the control handle down and the boom will lower.



Move the control handle to the left and the turntable will rotate left. Move the control handle to the right and the turntable will rotate right.



28 Platform level switch

Move the platform level switch up and the level of the platform will raise. Move the platform level switch down and the level of the platform will lower.



Inspections



Do Not Operate Unless:

- ☑ You learn and practice the principles of safe machine operation contained in this operator's manual.
 - 1 Avoid hazardous situations.
 - 2 **Always perform a pre-operation inspection.**
- Know and understand the pre-operation inspection before going on to the next section.**
- 3 Always perform function tests prior to use.
 - 4 Inspect the workplace.
 - 5 Only use the machine as it was intended.

Pre-operation Inspection Fundamentals

It is the responsibility of the operator to perform a pre-operation inspection and routine maintenance.

The pre-operation inspection is a visual inspection performed by the operator prior to each work shift. The inspection is designed to discover if anything is apparently wrong with a machine before the operator performs the function tests.

The pre-operation inspection also serves to determine if routine maintenance procedures are required. Only routine maintenance items specified in this manual may be performed by the operator.

Refer to the list on the next page and check each of the items.

If damage or any unauthorized variation from factory delivered condition is discovered, the machine must be tagged and removed from service.

Repairs to the machine may only be made by a qualified service technician, according to the manufacturer's specifications. After repairs are completed, the operator must perform a pre-operation inspection again before going on to the function tests.

Scheduled maintenance inspections shall be performed by qualified service technicians, according to the manufacturer's specifications and the requirements listed in the responsibilities manual.



Inspections

Pre-operation Inspection

- Be sure that the operator's, safety and responsibilities manuals are complete, legible and in the storage container located in the platform.
- Be sure that all decals are legible and in place. See Inspections section.
- Check for hydraulic oil leaks and proper oil level. Add oil if needed. See Maintenance section.
- Check for battery fluid leaks and proper fluid level. Add distilled water if needed. See Maintenance section.
- Check for engine oil leaks and proper oil level. Add oil if needed. See Maintenance section.
- Check for engine coolant leaks and proper level of coolant. Add coolant if needed. See Maintenance section.

Check the following components or areas for damage, improperly installed or missing parts and unauthorized modifications:

- Electrical components, wiring and electrical cables
- Hydraulic hoses, fittings, cylinders and manifolds
- Fuel and hydraulic tanks
- Drive and turntable motors and drive hubs
- Wear pads

- Tires and wheels
- Engine and related components
- Limit switches and horn
- Rotation sensors
- Steer and axle sensors
- Alarms and beacons (if equipped)
- Nuts, bolts and other fasteners
- Platform entry mid-rail or gate
- Platform load cell
- Lanyard anchorage points

Check entire machine for:

- Cracks in welds or structural components
- Dents or damage to machine
- Excessive rust, corrosion or oxidation
- Be sure that all structural and other critical components are present and all associated fasteners and pins are in place and properly tightened.
- After you complete your inspection, be sure that all compartment covers are in place and latched.

Inspections



Do Not Operate Unless:

- You learn and practice the principles of safe machine operation contained in this operator's manual.
 - 1 Avoid hazardous situations.
 - 2 Always perform a pre-operation inspection.
 - 3 Always perform function tests prior to use.**

Know and understand the function tests before going on to the next section.

- 4 Inspect the workplace.
- 5 Only use the machine as it was intended.

Function Test Fundamentals

The function tests are designed to discover any malfunctions before the machine is put into service. The operator must follow the step-by-step instructions to test all machine functions.

A malfunctioning machine must never be used. If malfunctions are discovered, the machine must be tagged and removed from service. Repairs to the machine may only be made by a qualified service technician, according to the manufacturer's specifications.

After repairs are completed, the operator must perform a pre-operation inspection and function tests again before putting the machine into service.



Inspections

At the Ground Controls

- 1 Select a test area that is firm, level and free of obstruction.
- 2 Turn the key switch to ground control.
- 3 Pull out the red Emergency Stop button to the on position.
- ⊙ Result: The beacons (if equipped) should flash.
- 4 Start the engine. See Operating Instructions section.

Test Emergency Stop

- 5 Push in the red Emergency Stop button to the off position.
- ⊙ Result: The engine should shut off and no functions should operate.
- 6 Pull out the red Emergency Stop button to the on position and restart the engine.

Test the Extendable Axles

Note: Start this test with the axles retracted.

- 7 At the ground controls, press and hold a function enable select button and press the boom up button.
- ⊙ Result: The boom should raise approximately 10° and then stop. On the LCD screen, the arrow next to the extend axle symbol will flash. The boom should not raise unless the axles are extended.
- 8 Press and hold a function enable select button and press the boom extend button.
- ⊙ Result: The boom should extend 30 cm then stop. On the LCD screen, the arrow next to the extend axle symbol will flash. The boom should not extend unless the axles are extended.
- 9 Push and hold a function enable select button and push the turntable rotate left button.
- ⊙ Result: The turntable should rotate 40° and then stop. The turntable should not rotate more than 40° unless the axles are extended.

- 10 Push and hold a function enable select button and push the turntable rotate right button.
- ⊙ Result: The turntable should return to center, rotate 40° to the right and then stop. The turntable should not rotate more than 40° unless the axles are extended.
- 11 Turn the key switch to platform control. At the platform controls, move the drive control handle in the forward direction and move the extend axle toggle switch.
- ⊙ Result: The machine should drive and the axles should extend. The axle extend and retract indicator lights will flash while the axles are moving and the axle extend light will stay on when the axles are fully extended.
- 12 Return to the ground controls. Turn the key switch to ground control.
- 13 Press and hold a function enable select button and press the boom up button and then the boom down button.
- ⊙ Result: The boom should raise and lower normally.
- 14 Push and hold a function enable select button and push the boom extend button and the boom retract.
- ⊙ Result: The boom should extend and retract normally.
- 15 Push and hold a function enable select button and push the turntable rotate left button and the turntable rotate right button.
- ⊙ Result: The turntable should rotate normally.



Inspections

Test Machine Functions

- 16 Do not press and hold a function enable select button. Attempt to activate each boom and platform function button.
 - ⊙ Result: No boom and platform functions should operate.
- 17 Press and hold a function enable select button and activate each boom and platform function button.
 - ⊙ Result: All boom and platform functions should operate through a full cycle. The descent alarm should sound while the boom is lowering.

Test Emergency Controls

- 18 Push in the red Emergency Stop button to the off position to shut off the engine.
- 19 Pull out the red Emergency Stop button to the on position.
- 20 Simultaneously push and hold the emergency power button and push each boom function button.



Note: To conserve battery power, test each function through a partial cycle.

- ⊙ Result: All boom functions should operate.
- 21 Start the engine.







Test the Tilt Sensor

- 22 Press one of the LCD screen control buttons until TURNTABLE LEVEL SENSOR X-DIRECTION appears.
 - ⊙ Result: The LCD screen should display the angle in degrees.
- 23 Press the LCD screen control buttons until TURNTABLE LEVEL SENSOR Y-DIRECTION appears.
 - ⊙ Result: The LCD screen should display the angle in degrees.
- 24 Press the LCD screen control buttons until PLATFORM LEVEL SENSOR DEGREES appears.
 - ⊙ Result: The LCD screen should display the angle in degrees.



Inspections

Test the Operating Envelope

- 25 Simultaneously press the 2 LCD screen control buttons shown to activate status mode.  
- 26 Press one of the LCD screen control buttons shown until PRIMARY ANGLE DEGREES is displayed.  
- 27 Raise the boom and observe the LCD screen.
- ⊙ Result: The LCD screen will display the boom angle to gravity in degrees.
- 28 Press one of the LCD screen control buttons shown until LENGTH SENSOR EXTENSION CM is displayed.  
- 29 Extend the boom and observe the LCD screen.
- ⊙ Result: The LCD screen will display the string pot extension length.
- 30 Retract the boom.

At the Platform Controls

Test Emergency Stop

- 31 Turn the key switch to platform control.
- 32 Push in the platform red Emergency Stop button to the off position.
- ⊙ Result: The engine should shut off and no functions should operate.
- 33 Pull out the red Emergency Stop button and restart the engine.

Test the Horn

- 34 Press the horn button.
- ⊙ Result: The horn should sound.

Test the Tilt Sensor Alarm

- 35 Move a toggle switch, such as the engine idle select switch.
- ⊙ Result: The alarm should sound at the platform controls.

Inspections

Test the Foot Switch

- 36 Push in the platform red Emergency Stop button to the off position.
- 37 Pull out the red Emergency Stop button to the on position and do not start the engine.
- 38 Press down the foot switch and attempt to start the engine by moving the start toggle switch to either side.
 - ⊙ Result: The engine should not start.
- 39 Do not press down the foot switch and restart the engine.
 - ⊙ Result: The engine should start.
- 40 Do not press down the foot switch and test each machine function.
 - ⊙ Result: No functions should operate.

Test Machine Functions

- 41 Press down the foot switch.
- 42 Activate each function control handle, toggle switch or thumb rocker switch.
 - ⊙ Result: All functions should operate through a full cycle.

Test the Steering

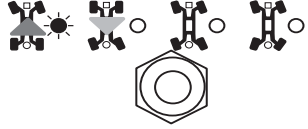
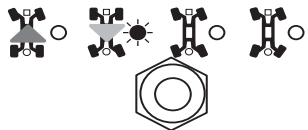
- 43 Move the steer mode select switch and choose square-end (blue arrow) steer.
 
- 44 Press down the foot switch.
- 45 Slowly move the drive control handle in the direction indicated by the blue triangle on the control panel OR press the thumb rocker switch in the direction indicated by the blue triangle.
 - ⊙ Result: The square-end wheels should turn in the direction that the blue triangles point on the drive chassis.
- 46 Slowly move the control handle in the direction indicated by the yellow triangle on the control panel OR press the thumb rocker switch in the direction indicated by the yellow triangle.
 - ⊙ Result: The square-end wheels should turn in the direction that the yellow triangles point on the drive chassis.
- 47 Move the steer mode select switch and choose circle-end (yellow arrow) steer.
 

Inspections

- 48 Press down the foot switch.
- 49 Slowly move the control handle in the direction indicated by the yellow triangle on the control panel OR press the thumb rocker switch in the direction indicated by the yellow triangle.
- ⊙ Result: The circle-end wheels should turn in the direction that the blue triangles point on the drive chassis.
- 50 Slowly move the drive control handle in the direction indicated by the blue triangle on the control panel OR press the thumb rocker switch in the direction indicated by the blue triangle.
- ⊙ Result: The circle-end wheels should turn in the direction that the yellow triangles point on the drive chassis.
- 51 Move the steer mode select switch and choose crab steer.
-
- 52 Press down the foot switch.
- 53 Slowly move the drive control handle in the direction indicated by the blue triangle on the control panel OR press the thumb rocker switch in the direction indicated by the blue triangle.
- ⊙ Result: All wheels should turn in the direction that the blue triangles point on the drive chassis.
- 54 Slowly move the control handle in the direction indicated by the yellow triangle on the control panel OR press the thumb rocker switch in the direction indicated by the yellow triangle.
- ⊙ Result: All wheels should turn in the direction that the yellow triangles point on the drive chassis.
- 55 Move the steer mode select switch and choose coordinated steer.
-
- 56 Press down the foot switch.
- 57 Slowly move the drive control handle in the direction indicated by the blue triangle on the control panel OR press the thumb rocker switch in the direction indicated by the blue triangle.
- ⊙ Result: The square-end wheels should turn in the direction that the blue triangles point on the drive chassis. The circle-end wheels should turn in the direction that the yellow triangles point on the drive chassis.
- 58 Slowly move the control handle in the direction indicated by the yellow triangle on the control panel OR press the thumb rocker switch in the direction indicated by the yellow triangle.
- ⊙ Result: The square-end wheels should turn in the direction that the yellow triangles point on the drive chassis. The circle-end wheels should turn in the direction that the blue triangles point on the drive chassis.

Inspections

Test Drive and Braking

- 59 Press down the foot switch.
- 60 Slowly move the drive control handle in the direction indicated by the blue arrow on the control panel until the machine begins to move, then return the handle to the center position.
 - ⊙ Result: The machine should move in the direction that the blue arrow points on the drive chassis, then come to an abrupt stop.
- 61 Slowly move the control handle in the direction indicated by the yellow arrow on the control panel until the machine begins to move, then return the handle to the center position.
 - ⊙ Result: The machine should move in the direction that the yellow arrow points on the drive chassis, then come to an abrupt stop.

Note: The brakes must be able to hold the machine on any slope it is able to climb.

Test the Drive Enable System

- 62 Press down the foot switch and lower the boom to the stowed position.
- 63 Rotate the turntable until the boom moves past a circle-end wheel and is outside of the range shown on the drive enable icon.
 - ⊙ Result: The drive enable indicator light should come on and remain on while the boom is anywhere outside of the range shown.
- 64 Move the drive control handle off center.
 - ⊙ Result: The drive function should not operate.
- 65 Move the drive enable toggle switch and slowly move the drive control handle off center.
 - ⊙ Result: The drive function should operate.



Note: When the drive enable system is in use, the machine may drive in the opposite direction that the drive and steer control handle is moved.

Use the color-coded direction arrows on the platform controls and the drive chassis to identify the direction of travel.

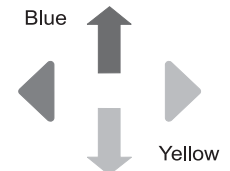

If the drive control handle is not moved within two seconds of moving the drive enable toggle switch, the drive function will not operate.



Inspections

Test Limited Drive Speed

- 66 Press down the foot switch.
- 67 Raise the boom to 10° above horizontal.
- 68 Slowly move the drive control handle to the full drive position.
- ⊙ Result: The maximum achievable drive speed with the primary boom raised should not exceed 18 cm per second.

Note: The machine will travel 12 m in 68 seconds.

- 69 Lower the boom to the stowed position.
- 70 Extend the boom 1.2 m.
- 71 Slowly move the drive control handle to the full drive position.
- ⊙ Result: The maximum achievable drive speed with the primary boom raised should not exceed 18 cm per second.

Note: The machine will travel 12 m in 68 seconds.

- 72 Raise the boom to 50° above horizontal and then extend the boom to maximum length.
- 73 Slowly move the drive control handle to the full drive position.
- ⊙ Result: The maximum achievable drive speed with the boom fully extended should not exceed 4.5 cm per second.

Note: The machine will travel 12 m in 270 seconds.

Test Drive Tilt Cutout

- 74 Press down the foot switch.
- 75 With the boom fully stowed, drive the machine onto a slope where the chassis angle is greater than 4.5° along the Y-Axis (front to back).
- ⊙ Result: The machine should continue to drive.
- 76 Return the machine to level ground and extend the boom approximately 91.4 cm.
- 77 Drive the machine onto a slope where the chassis angle is greater than 4.5° along the Y-Axis (front to back).
- ⊙ Result: The machine should stop once the machine reaches 4.5° of chassis tilt and the alarm should sound at the platform controls.
- 78 Retract the boom to the stowed position or drive in the opposite direction.
- ⊙ Result: The machine should drive.
- 79 Return to level ground and raise the boom to approximately 15° above horizontal.
- 80 Drive the machine onto a slope where the chassis angle is greater than 4.5° along the Y-Axis (front to back).
- ⊙ Result: The machine should stop once the machine reaches 4.5° of chassis tilt and the alarm should sound at the platform controls.
- 81 Lower the boom to the stowed position or drive in the opposite direction.
- ⊙ Result: The machine should drive.
- 82 Return to level ground and stow the boom.



Inspections

- 83 Press down the foot switch.
- 84 With the boom fully stowed, drive the machine onto a slope where the chassis angle is greater than 3° along the X-Axis (side to side).
 - ⊙ Result: The machine should continue to drive.
- 85 Return the machine to level ground and extend the boom approximately 91.4 cm.
- 86 Drive the machine onto a slope where the chassis angle is greater than 3° along the X-Axis (side to side).
 - ⊙ Result: The machine should stop once the machine reaches 3° of chassis tilt and the alarm should sound at the platform controls.
- 87 Retract the boom to the stowed position or drive in the opposite direction.
 - ⊙ Result: The machine should drive.
- 88 Return to level ground and raise the boom to approximately 15° above horizontal.
- 89 Drive the machine onto a slope where the chassis angle is greater than 3° along the X-Axis (side to side).
 - ⊙ Result: The machine should stop once the machine reaches 3° of chassis tilt and the alarm should sound at the platform controls.
- 90 Lower the boom to the stowed position or drive in the opposite direction.
 - ⊙ Result: The machine should drive.
- 91 Return to level ground and stow the boom.

Test Emergency Controls

- 92 Push in the red Emergency Stop button to the off position to shut off the engine.
- 93 Pull out the red Emergency Stop button to the on position.
- 94 Press down the foot switch.
- 95 Simultaneously move and hold the emergency power switch and activate each function control handle, toggle switch or thumb rocker switch.

Note: To conserve battery power, test each function through a partial cycle.

- ⊙ Result: All boom and steer functions should operate.

Test the Lift/Drive Select Function

- 96 Press down the foot switch.
- 97 Move the drive control handle off center and activate a boom function control handle.
 - ⊙ Result: No boom functions should operate. The machine will move in the direction indicated on the control panel.

Inspections



Do Not Operate Unless:

- You learn and practice the principles of safe machine operation contained in this operator's manual.
 - 1 Avoid hazardous situations.
 - 2 Always perform a pre-operation inspection.
 - 3 Always perform function tests prior to use.
 - 4 Inspect the workplace.**

Know and understand the workplace inspection before going on to the next section.

 - 5 Only use the machine as it was intended.

Workplace Inspection Checklist

Be aware of and avoid the following hazardous situations:

- drop-offs or holes
- bumps, floor obstructions or debris
- sloped surfaces
- unstable or slippery surfaces
- overhead obstructions and high voltage conductors
- hazardous locations
- inadequate surface support to withstand all load forces imposed by the machine
- wind and weather conditions
- the presence of unauthorized personnel
- other possible unsafe conditions

Workplace Inspection Fundamentals

The workplace inspection helps the operator determine if the workplace is suitable for safe machine operation. It should be performed by the operator prior to moving the machine to the workplace.

It is the operator's responsibility to read and remember the workplace hazards, then watch for and avoid them while moving, setting up and operating the machine.



Inspections

Inspection for Decals with Symbols

Use the pictures on the next page to verify that all decals are legible and in place.

Below is a numerical list with quantities and descriptions.

Part No.	Decal Description	Qty
27204	Arrow – Blue	2
27205	Arrow – Yellow	2
27206	Triangle – Blue	4
27207	Triangle – Yellow	4
28159	Label – Diesel	2
28235	Label – Power to platform	1
40434	Label – Lanyard Anchorage Point	8
44981	Label – Air Line to Platform (option)	2
52475	Label – Transport Tie Down	6
65278	Caution – No Step	6
72086	Label – Lifting Point	4
82481	Label – Battery/Charger Safety	2
82487	Label – Read the Manual	2
82487	Label – Read the Manual (pipe cradle)	2
97757	Label – Hydraulic Oil Level	1
97815	Label – Lower Mid-rail	2
114249	Label – Tip-over Hazard, Tires	4
114251	Label – Explosion Hazard	2
114252	Label – Tip-over Hazard, Limit Switches	7
114473	Label – Tilt Alarm	1
133067	Label – Electrocution Hazard	3
133205	Label – Electrocution/Burn Hazard	2
161686	Label – Emergency Lowering Instructions	1

Part No.	Decal Description	Qty
219958	Label – Tip-over, Crush Hazard	1
230984	Ground Control Panel	1
1254807	Label – 112 dB	1
1256420	Label – Power to Platform, 208V / 115V	1
1256421	Label – Power to Platform, 110V	1
1256422	Label – Power to Platform, 415V / 240V	1
1256424	Label – Tip-over Hazard anemometer	1
1256425	Label – Electrocution Hazard	1
1258677	Label – Power to Platform, 240V	1
1258678	Label – Power to Platform, 220V	1
1263542	Label – Compartment Access	4
1263544	Bypass Key Switch	1
1263545	Instructions – Bypass Key Switch	1
1270328	Label – Wheel Load, SX-125 XC	4
1270329	Label – Wheel Load, SX-105 XC	4
1270330	Cosmetic – Genie SX-125 XC	1
1272242	Label – Machine Registration / Owner Transfer	1
1272508	Label – Dual capacity SX-125	1
1275214	Label – Transport diagram	2
1275215	Label – Boom support	1
1278374	Label – Slope Rating	2
1279839	Label – Stow procedure	1
1280579	Cosmetic – Genie SX-105	1
1280580	Label – Dual capacity SX-105	1
T114286	Label – Install cover	8

■ Shading indicates decal is hidden from view, i.e. under covers

* These decals are model, option or configuration specific.

Inspections

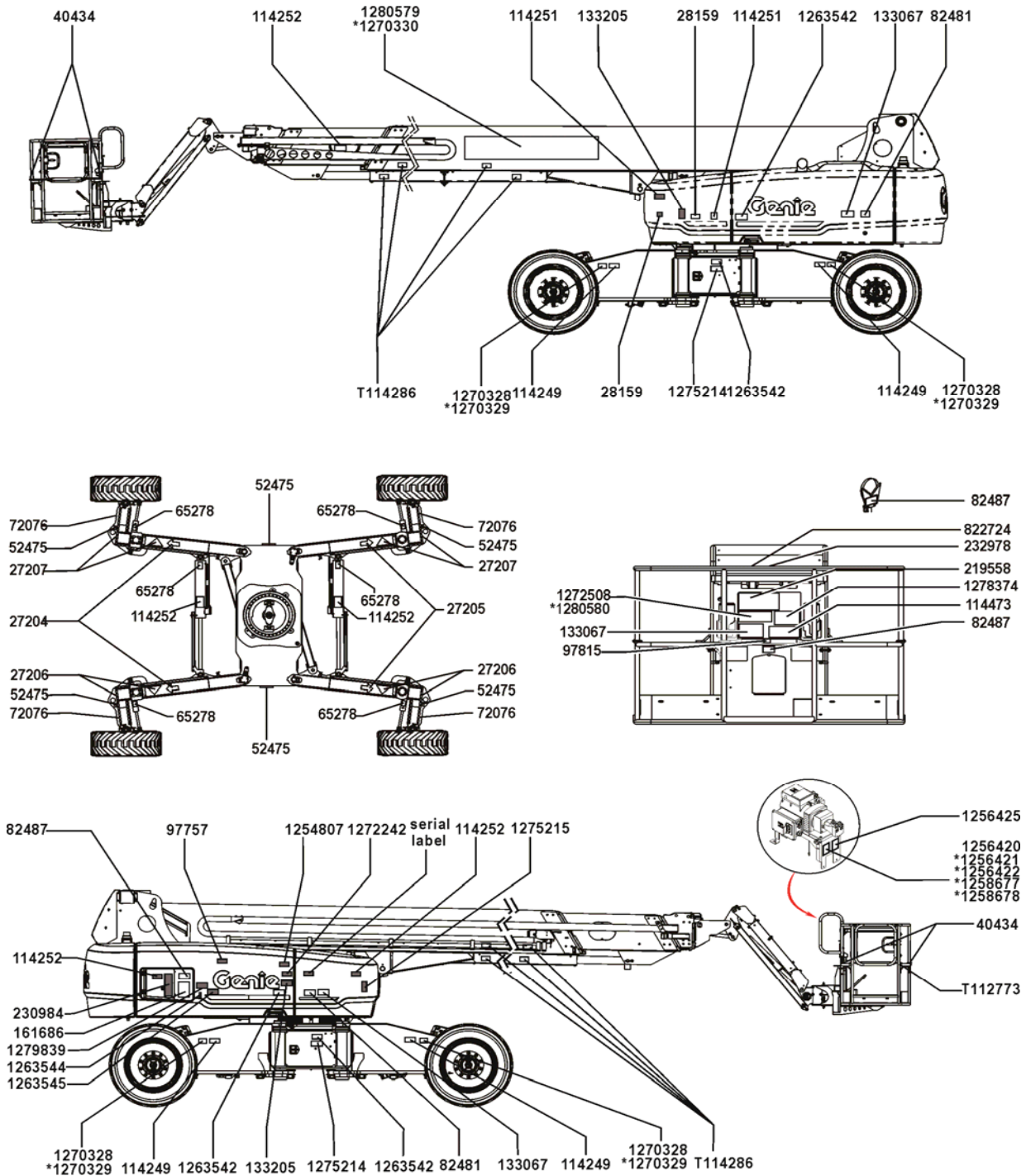

Operating Instructions



Do Not Operate Unless:

- You learn and practice the principles of safe machine operation contained in this operator's manual.
 - 1 Avoid hazardous situations.
 - 2 Always perform a pre-operation inspection.
 - 3 Always perform function tests prior to use.
 - 4 Inspect the workplace.
 - 5 **Only use the machine as it was intended.**

Fundamentals

The Operating Instructions section provides instructions for each aspect of machine operation. It is the operator's responsibility to follow all the safety rules and instructions in the operator's, safety and responsibilities manuals.

Using the machine for anything other than lifting personnel, along with their tools and materials, to an aerial work site is unsafe and dangerous.

Only trained and authorized personnel should be permitted to operate a machine. If more than one operator is expected to use a machine at different times in the same work shift, they must all be qualified operators and are all expected to follow all safety rules and instructions in the operator's, safety and responsibilities manuals. That means every new operator should perform a pre-operation inspection, function tests, and a workplace inspection before using the machine.



Operating Instructions

Starting the Engine

- 1 At the ground controls, turn the key switch to the desired position.
- 2 Be sure both ground and platform control red Emergency Stop buttons are pulled out to the on position.

Deutz models

- 3 Push the engine start button. The engine start button can be pushed at any time while the glow plugs are on. If the engine fails to start or dies, the restart delay will disable the start switch for 3 seconds.



Perkins models

- 1 Push the engine start button.

If the engine fails to start after 15 seconds of cranking, determine the cause and repair any malfunction. Wait 60 seconds before trying to start again.

In cold conditions, -6°C and below, warm the engine for 5 minutes before operating to prevent hydraulic system damage.

In extreme cold conditions, -18°C and below, machines should be equipped with optional cold start kits. Attempting to start the engine when temperatures are below -18°C may require the use of a booster battery.

Emergency Stop

Push in the red Emergency Stop button to the off position at the ground controls or the platform controls to stop all machine functions and turn the engine off.

Repair any function that operates when either red Emergency Stop button is pushed in.

Selecting and operating the ground controls will override the platform red Emergency Stop button.

Emergency Power

Use emergency power if the primary power source (engine) fails.

- 1 Turn the key switch to ground or platform control.
- 2 Pull out the red Emergency Stop button to the on position.
- 3 Press down the foot switch when using the controls from the platform.
- 4 Simultaneously hold the emergency power switch on and activate the desired function.



The drive functions will not operate with emergency power.

Operating Instructions

To Extend and Retract Axles

- 1 Turn the key switch to platform control.
- 2 At the platform controls, press down the foot switch and move the drive control handle in either direction and move the axle switch in the appropriate direction.

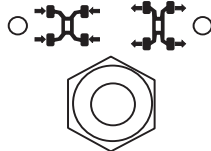

The axle extend and retract indicator lights will flash while the axles are moving. The axle extend indicator light will stay on when the axles are fully extended. The axle retract indicator light will stay on when the axles are fully retracted.

The axles can only be retracted if the boom is fully lowered and retracted and the platform is between the circle-end wheels.

Operation from Ground

- 1 Turn the key switch to ground control.
- 2 Pull out the red Emergency Stop button to the on position.
- 3 Start the engine.

To Position Platform

- 1 Push and hold a function enable button.
- 2 Push the appropriate function button according to the markings on the control panel.



Use the function speed select buttons to select function speed.



When the arrow above the turtle is lit, machines functions will operate at slow speed. When the arrow above the rabbit is lit, machines functions will operate at fast speed.

Drive and steer functions are not available from the ground controls.



Operating Instructions

Operation from Platform

- 1 Turn the key switch to platform control.
- 2 Pull out both ground and platform red Emergency Stop buttons to the on position.
- 3 Start the engine. Do not press down the foot switch when starting the engine.

To Position Platform

- 1 Press down the foot switch.
- 2 Slowly move the appropriate function control handle or thumb rocker switch or toggle switch according to the markings on the control panel.

To Steer

- 1 Press down the foot switch.
- 2 Select the steer mode by moving the steer mode switch. The indicator light next to the current steer mode will be on.

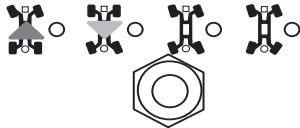

- 3 Slowly move the drive control handle in the direction indicated by blue or yellow triangles OR press the thumb rocker switch located on top of the drive control handle.



Use the color-coded direction arrows on the platform controls and the drive chassis to identify the direction the wheels will turn.

To Drive

- 1 Press down the foot switch.
- 2 Increase speed: Slowly move the drive control handle in the direction indicated by the blue or yellow arrows.

Decrease speed: Slowly move the drive control handle toward center.

Stop: Return the drive control handle to center or release the foot switch.



Use the color-coded direction arrows on the platform controls and the drive chassis to identify the direction the machine will travel.

Machine travel speed is restricted when the boom is raised or extended.

Operating Instructions

Driving on a slope

Determine the uphill, downhill and side slope ratings for the machine and determine the slope grade.



Maximum slope rating, platform downhill (gradeability):
40% (22°)



Maximum slope rating, platform uphill:
40% (22°)



Maximum side slope rating:
25% (14°)

Note: Slope rating is subject to ground conditions with one person in the platform and adequate traction. Additional platform weight may reduce slope rating. The term gradeability applies to the counterweight uphill configuration only.

Be sure the boom is below horizontal and the platform is between the circle-end wheels.

Move the drive speed select switch to machine on incline symbol.

To determine the slope grade:

Measure the slope with a digital inclinometer OR use the following procedure.

You will need:

- carpenter's level
- straight piece of wood, at least 1 m long
- tape measure

Lay the piece of wood on the slope.

At the downhill end, lay the level on the top edge of the piece of wood and lift the end until the piece of wood is level.

While holding the piece of wood level, measure the vertical distance from the bottom of the piece of wood to the ground.

Divide the tape measure distance (rise) by the length of the piece of wood (run) and multiply by 100.

Example:

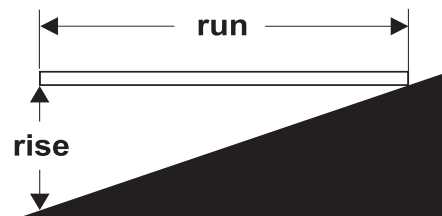

Piece of wood = 3.6 m

Run = 3.6 m

Rise = 0.3 m

$0.3 \text{ m} \div 3.6 \text{ m} = 0.083 \times 100 = 8.3\% \text{ grade}$

If the slope exceeds the maximum uphill, downhill or side slope rating, then the machine must be winched or transported up or down the slope. See Transport and Lifting section.

Operating Instructions

Drive Enable

Light on indicates that the boom has moved past a circle-end tire and the drive function has been interrupted.



To drive, move the drive enable switch and slowly move the drive/steer control handle off center.

If the drive/steer control handle is not moved within two seconds of moving the drive enable switch, the drive function will not operate. Release and move the drive enable switch again.

Be aware that the machine may move in the opposite direction that the drive and steer controls are moved.

Always use the color-coded direction arrows on the platform controls and the drive chassis to identify the direction the machine will travel.

When the drive enable light is on, the axles cannot retract.

Engine Idle Select (rpm)

Select the engine idle (rpm) by pressing the engine idle select switch. The indicator light next to the current setting will be on.

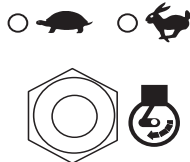

- Turtle symbol: low idle
- Rabbit symbol: high idle

Check Engine Light



Light on and engine stopped: Tag the machine and remove from service.

Light on and engine still running: Contact service personnel within 24 hours.

Operating Envelope Indicator Lights

The operating envelope indicator lights will come on to notify the operator that a function has been interrupted and/or an action is required by the operator.

Raise/Retract Boom indicator light flashing: Raise/retract the boom until the indicator light is off.

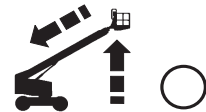

Lower Boom indicator light flashing: Lower the boom until the indicator light is off.

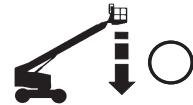

Machine Not Level indicator light flashing: The tilt alarm will be sounding when this light is flashing. Move the machine to a firm, level surface.



Operating Instructions

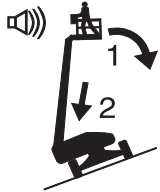

If the tilt alarm sounds with the platform uphill:

- 1 Lower the boom.
- 2 Retract the boom.

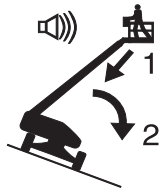

If the tilt alarm sounds with the platform downhill:

- 1 Retract the boom.
- 2 Lower the boom.

Platform Not Level indicator light flashing: The tilt alarm will be sounding when this light is flashing. The Platform Level toggle switch will only work in the direction that will level the platform. Level the platform until the indicator light is off.



Platform Out of Level (P22 code)

Bypass key position to be used to level the platform if ground control display shows platform out of level (P22) and platform level controls do not work.

To operate:

- 1 Turn the engine off.
- 2 Turn the main key switch to ground control. Remove the key from the main key switch and insert the key into the bypass/recovery key switch.
- 3 Turn the bypass/recovery key switch to the bypass position.
- 4 Using emergency power, operate the platform level button to level the platform.
- 5 Turn the bypass/recovery key switch to the run position.
- 6 Remove the key from the bypass/recovery key switch and insert the key into the main key switch.
- 7 Push in and then pull out the red Emergency Stop button.
- 8 If the P22 code is still visible, tag and remove the machine from service until the fault has been corrected by a qualified service technician.





Operating Instructions

Platform Out of Level (Platform Level > 15 Degrees Fault)

If ground control display shows PLATFORM LEVEL > 15 DEGREES FAULT and the platform level controls do not work, the machine will need to be recovered by trained and authorized personnel or a qualified service technician.

Platform Overload Indicator Light



Light flashing indicates the platform is overloaded and no functions will operate.

Remove weight from the platform until the light goes off and then restart the engine.

Overload Recovery

If the ground controls LCD screen displays OVERLOAD RECOVERY, the emergency lowering system has been used while the platform was overloaded. For information on how to reset this message, please consult the appropriate Genie Service Manual.

Generator

To operate the generator, move the generator toggle switch.

Note: If the foot switch is activated during generator start-up, the generator will not operate.

The generator indicator light will flash during generator start-up. After generator start-up is complete, the generator indicator light will stay lit and the engine rpm will move into high rpm, rabbit symbol mode.

Plug a power tool into the power to platform GFCI outlet. There is GFCI protection built into the generator electrical box, located on the turntable chassis.

To turn off the generator, move the generator toggle switch. The generator indicator light will flash during generator shut-down sequence. After the generator shut-down sequence is complete the generator indicator light will turn off and the engine rpm will move into low rpm, turtle symbol mode.

Operating Instructions

Platform Capacity Selection

Range of motion is controlled automatically based on platform load.

Unrestricted Range of Motion:
When the platform load is less than 300 kg, the unrestricted range of motion light is on.



Restricted Range of Motion:
When the platform load is 301-454 kg, the restricted range of motion light is on and the jib function is limited.



LCD Screen (if equipped)

The LCD screen displays hour meter, voltage, oil pressure and coolant temperature. The screen also displays fault codes and other service information.

Perkins Engine

Machines equipped with Perkins 854F-34T Diesel engines have a regeneration mode that should run automatically when needed.

LCD will display **REGEN FORCED** and **WARNING HIGH EXHAUST SYSTEM TEMP** when the regeneration mode is running. No service required.

After Each Use

- 1 Select a safe parking location—firm level surface, clear of obstruction and traffic.
- 2 Retract and lower the boom to the stowed position.
- 3 Rotate the turntable until the boom is positioned between the circle end wheels.
- 4 Turn the key switch to the off position and remove the key to secure from unauthorized use.

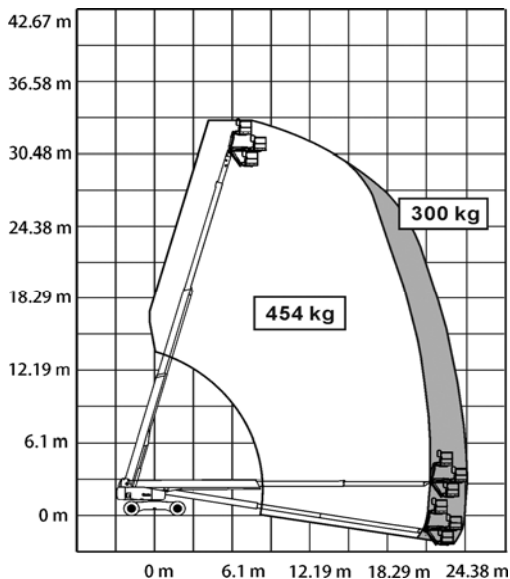
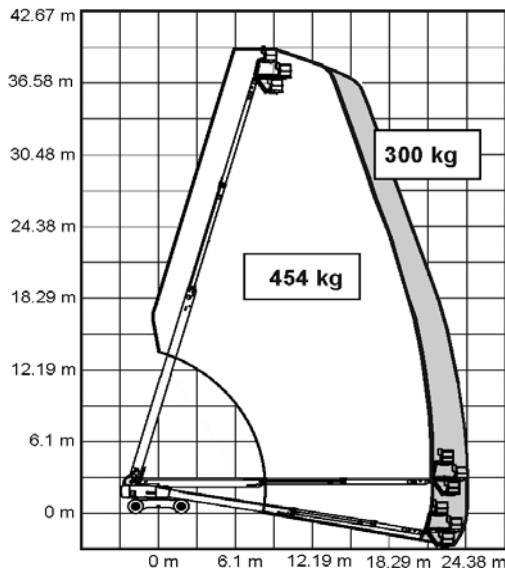

Operating Instructions

Pipe Cradle Instructions

The pipe cradle assembly consists of 2 pipe cradles positioned at either side of the platform and mounted to the guardrails with U-bolts.

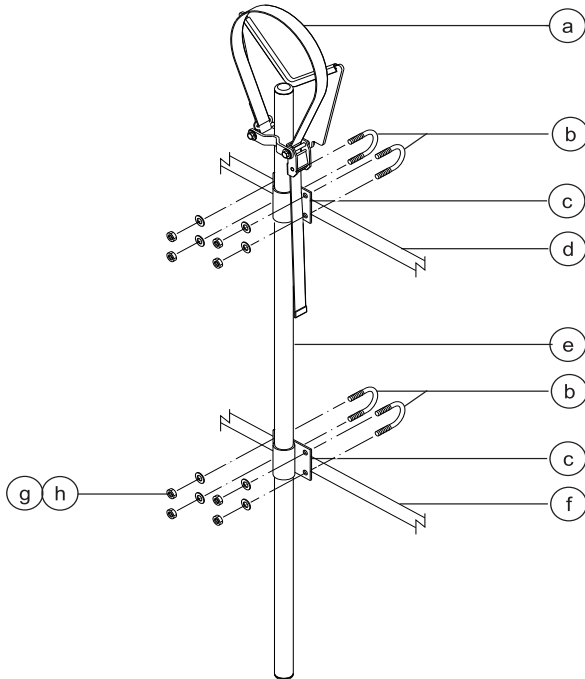

- a strap
- b U-bolts
- c pipe cradle mount
- d upper platform railing
- e pipe cradle weldment
- f middle platform railing
- g flat washers
- h nylock nuts

Observe and Obey:

- Pipe cradles must be installed on the inside of the platform.
- Pipe cradles must not obstruct the platform controls or the platform entrance.
- The bottom of the pipe cradle tube must rest on the platform floor.
- Be sure the platform is level before installing a pipe cradle.

Pipe Cradle Installation

- 1 Install a pipe cradle on each side of the platform. Refer to the illustration on the left. Make sure the bottom of the pipe cradle tube rests on the platform floor.
- 2 Install two U-bolts from the outside of the platform rails through each pipe cradle mount.
- 3 Secure each U-bolt with 2 washers and 2 nuts.



Operating Instructions

Pipe Cradle Operation

- 1 Be sure the pipe cradle assembly and installation instructions have been followed properly and that the pipe cradles are secured to the platform railings.
 - 2 Place the load so that it rests in both pipe cradles. The length of the load should be parallel with the length of the platform.
 - 3 Center the load in the pipe cradles.
 - 4 Secure the load to each pipe cradle. Pass the nylon strap over the load. Depress the buckle and slide the strap through. Tighten the strap.
 - 5 Gently push and pull on the load to make sure the pipe cradles and load are secure.
 - 6 Keep the load secured when the machine is moving.
- ▲ Tip-over hazard. The weight of the pipe cradle assembly and the load in the pipe cradles will reduce the rated platform capacity of the machine and must be factored into the total platform load.
 - ▲ Tip-over hazard. The weight of the pipe cradle assembly and the load in the pipe cradles may limit the maximum number of occupants in the platform.

Maximum Pipe Cradle Capacity

All models	90.7 kg
Pipe Cradle Assembly Weight	9.5 kg

Transport and Lifting Instructions



Observe and Obey:

- ☑ Genie provides this securement information as a recommendation. Drivers are solely responsible for making sure machines are properly secured and the correct trailer is selected pursuant to US Department of Transportation regulations, other localized regulations, and their company policy.
- ☑ Genie customers needing to containerize any lift or Genie product should source a qualified freight forwarder with expertise in preparing, loading and securing construction and lifting equipment for international shipment.
- ☑ Only qualified aerial lift operators should move the machine on or off the truck.
- ☑ The transport vehicle must be parked on a level surface.
- ☑ The transport vehicle must be secured to prevent rolling while the machine is being loaded.
- ☑ Be sure the vehicle capacity, loading surfaces and chains or straps are sufficient to withstand the machine weight. Genie lifts are very heavy relative to their size. See the serial label for the machine weight.

- ☑ Be sure the turntable is secured with the turntable rotation lock before transporting. Be sure to unlock the turntable for operation.
- ☑ Do not drive the machine on a slope that exceeds the uphill, downhill or side slope rating. See Driving on a Slope in the Operating Instructions section.
- ☑ If the slope of the transport vehicle bed exceeds the maximum slope rating, the machine must be loaded and unloaded using a winch as described in the brake release operation.

Free-wheel Configuration for Winching

Chock the wheels to prevent the machine from rolling.

Release the wheel brakes by turning over all four drive hub disconnect caps.

Be sure the winch line is properly secured to the drive chassis tie points and the path is clear of all obstructions.

Reverse the procedures described to re-engage the brakes.

Note: The pump free-wheel valve should always remain closed.

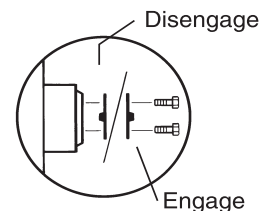

Transport and Lifting Instructions

Securing to Truck or Trailer for Transit

Always use the turntable rotation lock pin each time the machine is transported.

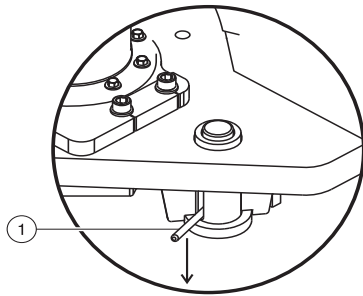

1 Turntable rotation lock pin

Turn the key switch to the off position and remove the key before transporting.

Inspect the entire machine for loose or unsecured items.

Securing the Platform

Lower the jib to the stowed position.

Lower the platform as far as it will go, so that the jib and platform are tucked underneath the boom.

Run a strap through the platform support between the plates next to the rotator.

Anchor the strap to each corner of the truck bed.

The platform will hang over the end of the truck.

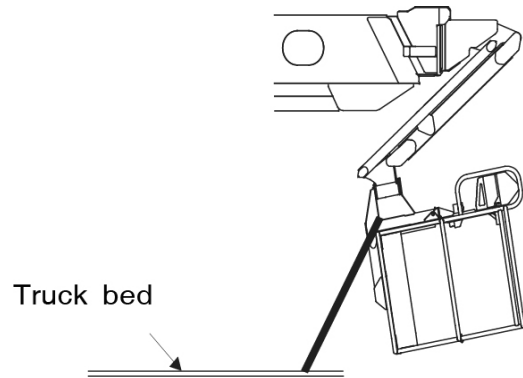

Transport and Lifting Instructions

SX-105 XC

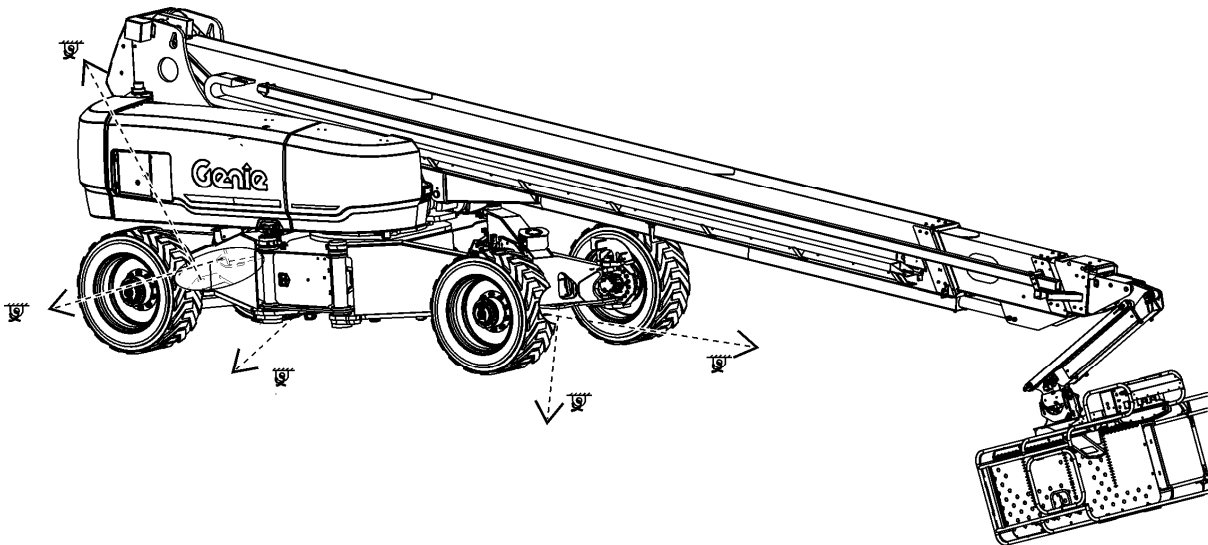
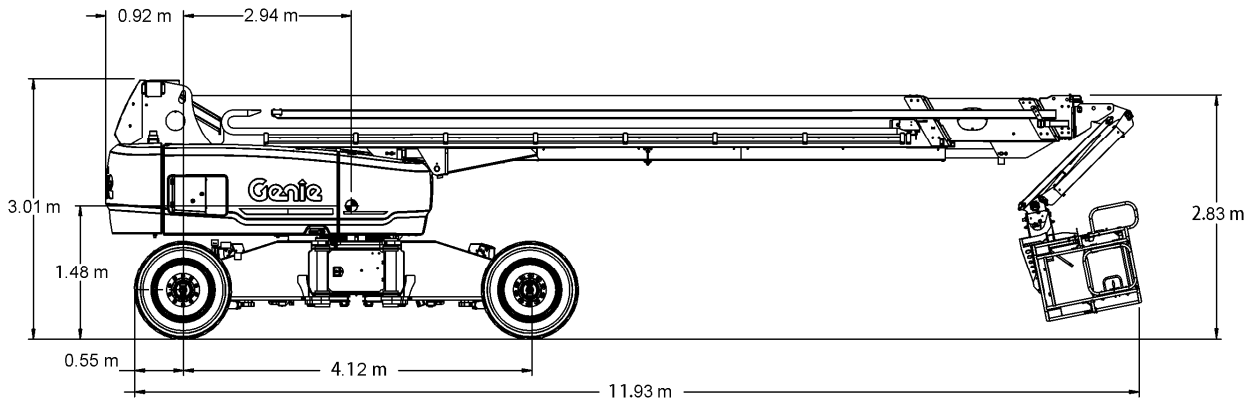

Transport and Lifting Instructions

SX-125 XC

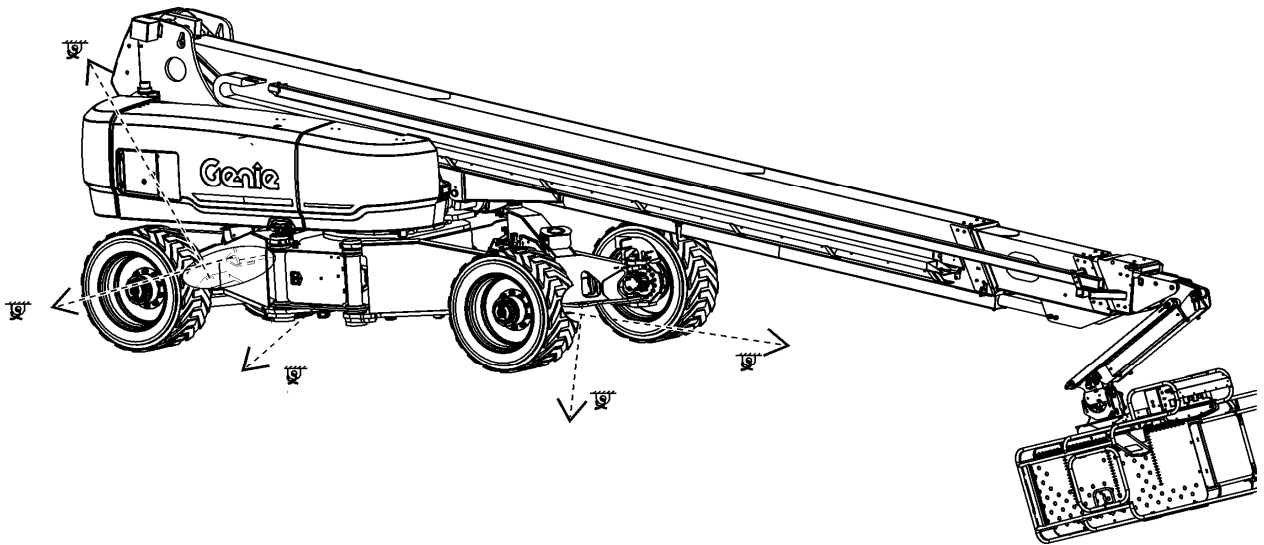
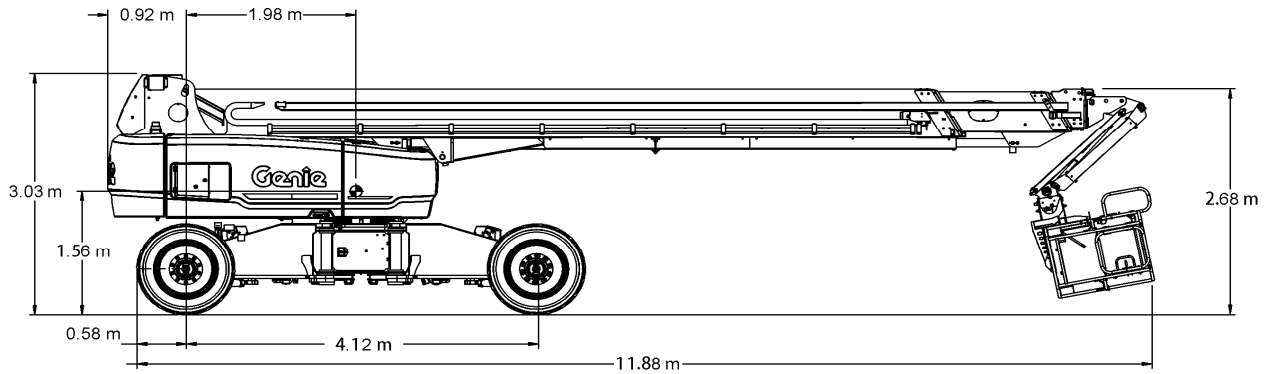

Transport and Lifting Instructions



Observe and Obey:

- ☑ Only qualified riggers should rig the machine.
- ☑ Only certified crane operators should lift the machine and only in accordance with the applicable crane regulations.
- ☑ Be sure the crane capacity, loading surfaces and straps or lines are sufficient to withstand the machine weight. See the serial label for the machine weight.

Lifting Instructions

Fully extend the axles. Fully lower and retract the boom. Fully lower the jib.

Remove all loose items on the machine.

Determine the center of gravity of your machine using the table and the picture on this page.

Attach the rigging only to the designated lifting points on the machine. There are four lifting points on the machine, one on each axle.

Adjust the rigging to prevent damage to the machine and to keep the machine level.

Center of gravity	X Axis	Y Axis
SX-105 XC	2.9 m	1.5 m
SX-125 XC	3.3 m	1.6 m

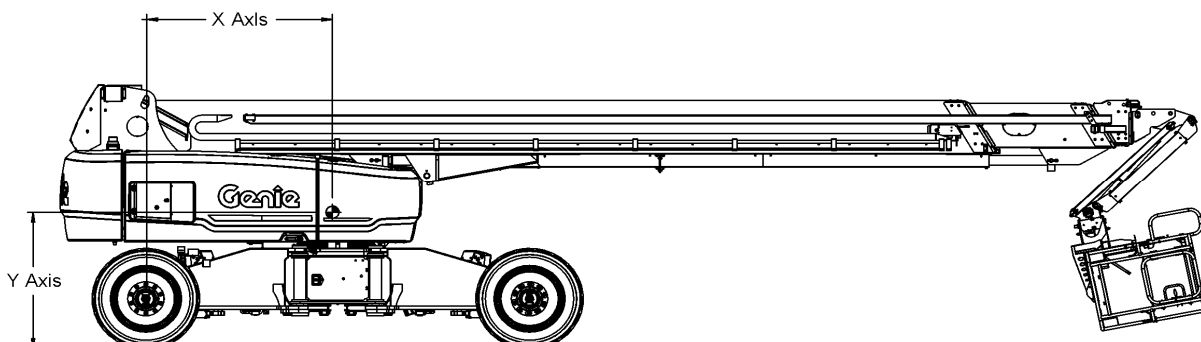
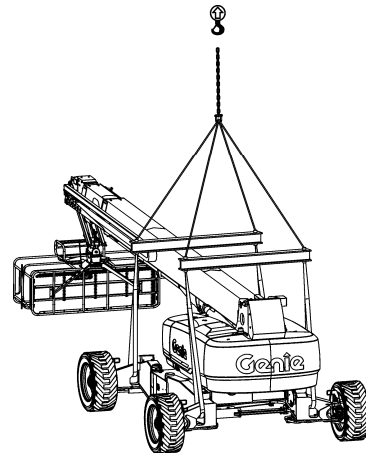

Maintenance



Observe and Obey:

- Only routine maintenance items specified in this manual shall be performed by the operator.
- Scheduled maintenance inspections shall be completed by qualified service technicians, according to the manufacturer's specifications and the requirements specified in the responsibilities manual.
- Dispose of material in accordance with governmental regulations.
- Use only Genie approved replacement parts.

Maintenance Symbols Legend

The following symbols have been used in this manual to help communicate the intent of the instructions. When one or more of the symbols appear at the beginning of a maintenance procedure, it conveys the meaning below.



Indicates that tools will be required to perform this procedure.



Indicates that new parts will be required to perform this procedure.



Indicates that a cold engine is required before performing this procedure.

Check the Engine Oil Level



Maintaining the proper engine oil level is essential to good engine performance and service life. Operating the machine with an improper oil level can damage engine components.

Note: Check the oil level with the engine off.

- 1 Check the oil level dipstick. Add oil as needed.

Perkins 1104D-44T Engine

Oil type	15W-40
Oil type - cold conditions	10W-30

Deutz TD2011 L04i Engine

Oil type	15W-40
Oil type - cold conditions	5W-30

Perkins 854F-34T Engine

Oil type	15W-40
Oil type - cold conditions	5W-30

Deutz TD2.9L Engine

Oil type	15W-40
Oil type - cold conditions	5W-30



Maintenance

Diesel Fuel Requirements



Satisfactory engine performance is dependent on the use of a good quality fuel. The use of a good quality fuel will give the following result: long engine life and acceptable exhaust emissions levels.

Minimum diesel fuel requirements for each engine are listed below.

Perkins 1104D-44T Engine	
Fuel Type	Low Sulfur Diesel (LSD)
Perkins 854F-34T Engine	
Fuel Type	Ultra Low Sulfur Diesel (ULSD)
Deutz TD2011 L04i Engine	
Fuel Type	Low Sulfur Diesel (LSD)
Deutz TD2.9L Engine	
Fuel Type	Ultra Low Sulfur Diesel (ULSD)

Check the Hydraulic Oil Level



Maintaining the hydraulic oil at the proper level is essential to machine operation. Improper hydraulic oil levels can damage hydraulic components. Daily checks allow the inspector to identify changes in oil level that might indicate the presence of hydraulic system problems.

- 1 Be sure that the boom is in the stowed position, then visually inspect the sight gauge located on the side of the hydraulic oil tank. Add oil as needed.
- ⊙ Result: The hydraulic oil level should be within the top 5 cm of the sight gauge.

Hydraulic oil specifications

Hydraulic oil type	Chevron Rando equivalent
--------------------	--------------------------

Maintenance

Check the Batteries



Proper battery condition is essential to good machine performance and operational safety. Improper fluid levels or damaged cables and connections can result in engine component damage and hazardous conditions.

- ▲ **Electrocution hazard.** Contact with hot or live circuits may result in death or serious injury. Remove all rings, watches and other jewelry.
- ▲ **Bodily injury hazard.** Batteries contain acid. Avoid spilling or contacting battery acid. Neutralize battery acid spills with baking soda and water.

Note: The controls battery is below the start battery.

- 1 Put on protective clothing and eye wear.
- 2 Be sure that the battery cable connections are tight and free of corrosion.
- 3 Be sure that the battery hold-down bar is secure.

Note: Adding terminal protectors and a corrosion preventative sealant will help eliminate corrosion on the battery terminals and cables.

Check the Engine Coolant Level – Liquid Cooled Models



Maintaining the engine coolant at the proper level is essential to engine service life. Improper coolant level will affect the engine's cooling capability and damage engine components. Daily checks will allow the inspector to identify changes in coolant level that might indicate cooling system problems.

- 1 Check the coolant fluid level. Add fluid as needed.
 - Result (Deutz TD2.9L engine): The fluid level should be visible in the sight gauge on the degas tank.
 - Result (all other engine models): The fluid level should be in the NORMAL range.
- ▲ **Bodily Injury Hazard.** Fluids in the radiator and in the degas tank are under pressure and extremely hot. Use caution when removing cap and adding fluids.

Scheduled Maintenance

Maintenance performed quarterly, annually and every two years must be completed by a person trained and qualified to perform maintenance on this machine according to the procedures found in the service manual for this machine.

Machines that have been out of service for more than three months must receive the quarterly inspection before they are put back into service.



Specifications

Model	SX-105 XC
Height, working maximum	34.00 m
Height, platform maximum	32.00 m
Height, stowed maximum	3.0 m
Horizontal reach, maximum	24.38 m
Below ground reach	2.46 m
Width, axles retracted	2.51 m
Width, axles extended	3.97m
Length, stowed	14.15 m
Length, stowed for transport (jib stowed for transport)	12.42 m
Maximum load capacity, Restricted range of motion	300 kg
Maximum load capacity, Restricted range of motion	454 kg
Maximum wind speed	12.5 m/s
Wheelbase	4.11 m
Ground clearance	35.6 cm
Turning radius, axles extended	
Inside	3.05 m
Outside	6.48 m
Turning radius, axles retracted	
Inside	8.15 m
Outside	9.78 m
Turntable rotation (degrees)	360° continuous
Turntable tail swing, axles extended	0.99 m
Turntable tail swing, axles retracted	0.38 m
Controls	12V DC proportional
Platform dimensions, 1.8 m (length x width)	183 x 76 cm
Platform dimensions, 2.4 m (length x width)	244 x 91 cm
Platform leveling	self-leveling
Platform rotation	160°
Vertical jib rotation	135°
AC outlet in platform	standard
Fuel tank capacity	40 gal
Hydraulic pressure, maximum (boom functions)	203 bar
Hydraulic pressure, maximum (auxiliary power unit)	221 bar

System voltage	12V
Tire size	IN385/65D 22.5
Weight	18,605 kg

(Machine weights vary with option configurations. See serial label for specific machine weight.)

Airborne noise emissions

Sound pressure level at ground workstation	<91 dBA
Sound pressure level at platform workstation	<75 dBA
Guaranteed sound power level	112 dBA

Total vibration value to which the hand/arm system is subjected does not exceed 2.5 m/s²

Highest root mean square value of weighted acceleration to which the whole body is subjected does not exceed 0.5 m/s².

Maximum slope rating, stowed position, 4WD

Counterweight uphill	40%	22°
Counterweight downhill	40%	22°
Side slope	25%	14°

Note: Slope rating is subject to ground conditions with one person in the platform and adequate traction. Additional platform weight may reduce slope rating.

Drive speeds

Drive speed, stowed	4.8 km/h	12 m/8.8 sec
Drive speed, raised or extended	1.09 km/h	12 m/39 sec
Drive speed, boom extend over 24.4 m	0.61 km/h	12 m/75 sec

Floor loading information

Tire load maximum	9,637 kg
Tire contact pressure	7.13 kg/cm ² 700 kPa
Occupied floor pressure (axles extended)	899 kg/m ² 8.81 kPa
Occupied floor pressure (axles retracted)	1421 kg/m ² 13.93 kPa

Note: Floor loading information is approximate and does not incorporate different option configurations. It should be used only with adequate safety factors.

Continuous improvement of our products is a Genie policy. Product specifications are subject to change without notice or obligation.



Model	SX-125 XC
Height, working maximum	40.10 m
Height, platform maximum	38.10 m
Height, stowed maximum	3.05 m
Horizontal reach, maximum	24.38 m
Below ground reach	2.69 m
Width, axles retracted	2.49 m
Width, axles extended	3.94 m
Length, stowed	14.25 m
Length, stowed for transport (jib stowed for transport)	12.19 m
Maximum load capacity, Restricted range of motion	300 kg
Maximum load capacity, Restricted range of motion	454 kg
Maximum wind speed	12.5 m/s
Wheelbase	4.11 m
Ground clearance	38.1 cm
Turning radius, axles extended	
Inside	2.9 m
Outside	6.17 m
Turning radius, axles retracted	
Inside	8.03 m
Outside	9.96 m
Turntable rotation (degrees)	360° continuous
Turntable tailswing, axles extended	1.02 m
Turntable tailswing, axles retracted	0.56 m
Controls	12V DC proportional
Platform dimensions, 1.8 m (length x width)	183 x 76 cm
Platform dimensions, 2.4 m (length x width)	244 x 91 cm
Platform leveling	self-leveling
Platform rotation	160°
Vertical jib rotation	135°
AC outlet in platform	standard
Fuel tank capacity	151 liters
Hydraulic pressure, maximum (boom functions)	203 bar
Hydraulic pressure, maximum (auxiliary power unit)	221 bar

System voltage	12V
Tire size	445D50/710, 18 ply HD FF
Weight	20,700 kg

(Machine weights vary with option configurations. See serial label for specific machine weight.)

Airborne noise emissions

Sound pressure level at ground workstation	<91 dBA
Sound pressure level at platform workstation	<75 dBA
Guaranteed sound power level	112 dBA

Total vibration value to which the hand/arm system is subjected does not exceed 2.5 m/s²

Highest root mean square value of weighted acceleration to which the whole body is subjected does not exceed 0.5 m/s².

Maximum slope rating, stowed position, 4WD

Counterweight uphill	40% 22°
Counterweight downhill	40% 22°
Side slope	25% 14°

Note: Slope rating is subject to ground conditions with one person in the platform and adequate traction. Additional platform weight may reduce slope rating.

Drive speeds

Drive speed, stowed	4.8 km/h 12 m/8.8 sec
Drive speed, raised or extended	1.09 km/h 12 m/40 sec
Drive speed, boom extend over 24.4 m	0.61 km/h 12 m/71 sec

Floor loading information

Tire load maximum	10,086 kg
Tire contact pressure	7.13 kg/cm ² 700 kPa
Occupied floor pressure (axles extended)	1001 kg/m ² 9.81 kPa
Occupied floor pressure (axles retracted)	1583 kg/m ² 15.52 kPa

Note: Floor loading information is approximate and does not incorporate different option configurations. It should be used only with adequate safety factors.

Continuous improvement of our products is a Genie policy. Product specifications are subject to change without notice or obligation.

SX-105 XC Range of Motion Chart

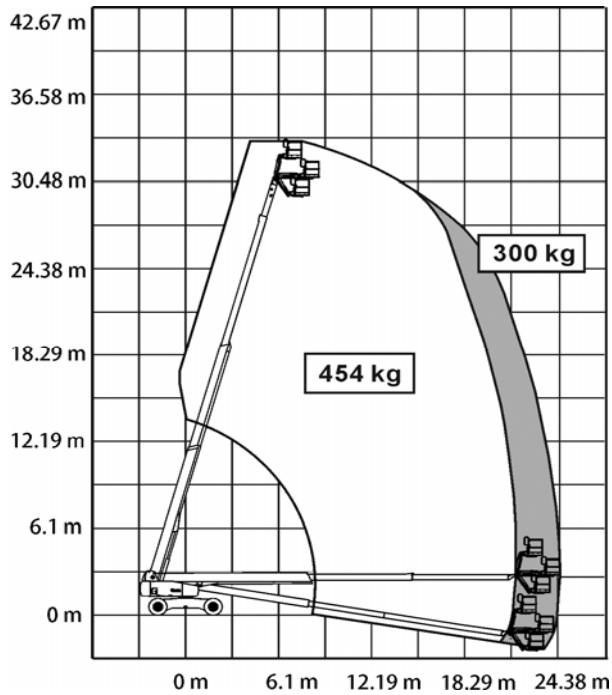

SX-125 XC Range of Motion Chart

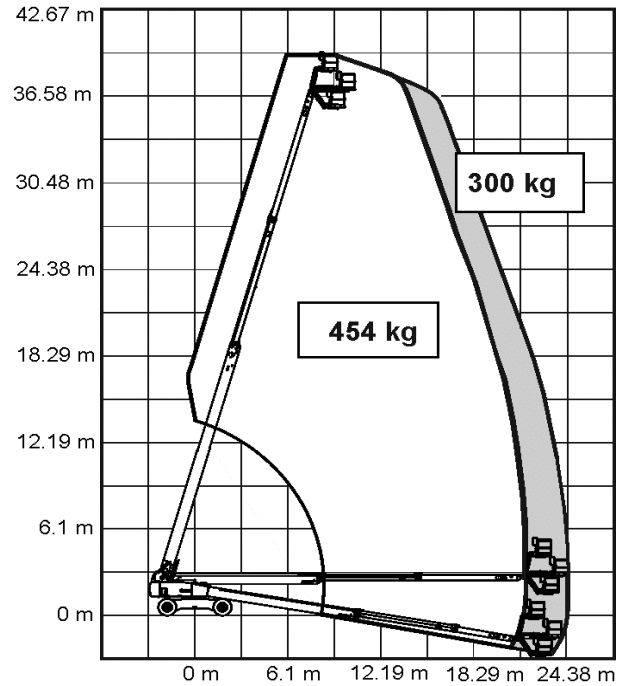



www.genielift.com

Distributed By: